

MODEL

MEGA ARM™

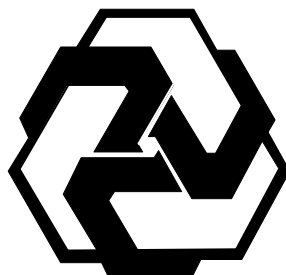

COMMERCIAL DUTY PARKING GATE OPERATOR
(ALSO FOR MEGA SPRINT)



INSTALLATION AND SERVICE MANUAL
IMPORTANT INSTALLATION INSTRUCTIONS-DO NOT DISCARD

(IMPORTANT: READ AND UNDERSTAND WARRANTY PAGE FIRST)

THIS MANUAL COVERS THE NEW INTER-LOCK MEMORY FEATURES

WARNING! CHILDREN SHOULD NEVER BE ALLOWED TO PLAY NEAR OR OPERATE AUTOMATIC GATES. FAILURE TO OBSERVE SAFE OPERATING PROCEDURE, TRAIN YOUR CUSTOMER PROPERLY OR INSTALL PROPER WARNING SIGNAGE MAY RESULT IN SERIOUS INJURY.

DC SOLUTIONS, INC

**4750 S.W. 36 STREET. BLDG-X
FT. LAUDERDALE, FLORIDA 33314**

(954)-327-0988

TABLE OF CONTENTS

INTRODUCTION

UNIT OVERVIEW.....	1
--------------------	---

INSTALLATION PROCEDURE

CONCRETE PAD.....	1
ANCHORS.....	1
CONDUITS.....	2
DIMENSIONS.....	12

WIRING AND HOOKUP

120 VOLTS AC.....	2
INPUT COMMANDS 1-8	2
ACCESSORY AND RELAY CONNECTIONS.....	3
BATTERY INSTALLATION.....	3
MASTER / SLAVE WIRING.....	4
REVERSING ARM DIRECTION.....	11

TIMERS AND MODE SELECTIONS S1 & S2

MODE SELECTIONS - S1.....	5
MODE SELECTIONS - S2	5
CLOSE TIMER SELECTION - S2.....	5

ADJUSTMENTS

INSTANT REVERSE DEVICE (IRD).....	6
GATE ARM LEVELING.....	6

TROUBLE SHOOTING AND MAINTENANCE PROCEDURES

BATTERY CHECK OUT.....	7
GATE NOT OPERATING.....	7
GENERAL SERVICE.....	7
SHEAR PIN REPLACEMENT.....	6

SAMPLE CONFIGURATIONS

FREE EXIT OPERATION.....	8
ENTRY WITH ACCESS CONTROL DEVICE.....	8
DUAL DIRECTION.....	8
INTERLOCK MEGA ARMS OR WITH OTHER OPERATORS.....	13

CONTROL BOARD LAYOUT

INPUT LOCATIONS.....	9
----------------------	---

MEGA-ARM PARTS LIST

PART NUMBERS AND DESCRIPTIONS.....	10
PARTS SHIPPED.....	10

INTRODUCTION

UNIT OVERVIEW

The DC SOLUTIONS model MEGA-ARM barrier style parking gate operator is unique in the industry. Setting the MEGA-ARM apart are many features that make it the front runner in its class. With standard features like:

- Built in battery backup - inherent 24 VDC backup power with regulated 24VDC for accessories.
- High torque 24 volt Permanent Magnet DC motor .
- Full service controller with eight inputs and LED indicators for loops, card reader, radio, etc...
- Continuous duty operation for all applications (6k per day, SPRINT version 10k per day).
- Reversible arm direction for right or left handed operation.
- Instant Reverse Device (**IRD**) monitor senses obstructions going open and close.
- Automatic open of gate arm when power is lost if desired (With 15 sec. delay selection).
- Raise gate input memory will memorize multiple vehicles-ideal for barcode scanners & AVI.
- Ability to have arm STOP in close travel if tail-gating is sensed at close loop.
- Anti-tail gate alarm - fires K1 relay to trigger a warning device when tail-gating is sensed.
- Interlock with memory- allows Mega Arm to open a slide/swing gate first then raises arm.
- Break away mounting design for the 12 -15 foot by 3" tubular aluminum arm.
- All rust proof aluminum construction with white powder coat baked on enamel.
- Molded Polyethylene UV stabilized cover never needs wax or paint
- Direct drive gear reducer eliminates many parts that might otherwise fail.
- Microprocessor (RISC) based electronics with watch dog reset timer.
- State of the art MOSFET motor drive technology, NO contactors or relays.
- Dynamic motor braking to preserve arm positioning.
- Soft start and stop in open and close travel motions.
- No limit switches to fail-uses magnetic (Hall Effect) sensors to monitor arm position.
- Maximum Run Timer for motor (MRT) with anti-tamper protection in closing direction.
- Each unit configurable as master or slave operator.
- Safe 24 VDC low voltage motor and control wiring.
- Open architecture PCB with space for OVERDRIVE CPU for future expanded options.
- LED diagnostic center for easy on-site trouble shooting.
- Closing timer adjustable from 1-33 seconds with on / off selection.
- Transorb diodes on all inputs for protection against transient voltage spikes.
- Capable of being powered by 120 VAC, 220 VAC or Solar power, standard.
- Duplex outlet gives convenient supply of 120 VAC for transformers and 120 VAC accessories.
- 5 year perforation warranty on cover and chassis with 1 year on electronics and mechanism.

INSTALLATION PROCEDURE

CONCRETE PAD

The concrete pad for operator mounting should be approximately 24"x24"x24" in order to provide adequate weight and structure to insure proper and stable operation. Pad should be 6" above finished grade or even with top of curb if one is present. **(NOTE: PAD SHOULD ALWAYS GO BELOW FROST LINE IN REGIONS WHERE GROUND WILL FREEZE!!)**

ANCHORS

Proper anchors for fastening operator to pad will be a 1/2"x6" wedge anchor patterned to match the mounting base of the unit. They should be installed with approximately 1.25" showing above concrete surface in order to allow for the 1/2" thick base plate as well as washers for leveling.

NOTE 1: MAXIMUM AMBIENT TEMPERATURE FOR INSTALLATION, 104 FAHRENHEIT.
NOTE 2: FOR AUTOMOTIVE USE ONLY, NO MOTORCYCLES, BICYCLES OR PEDESTRIANS.
NOTE 3: HEATER OPTION MUST BE USED IF TEMP IS (15F) OR BELOW TEMPERATURES.

CONDUITS

Conduits should be restricted to fit the 3.5"x3.5" opening in pedestal base. Location on pad should be centered and spaced approximately 6" from edge of pad on drive way side (in order to get the most reach out of arm). Conduits to be included should be 120 VAC main power, low voltage control wiring and one or two extra for loop sensor leads. Conduit size should be limited to .5" when possible to reduce crowding if more than four are needed. All conduits must be U.L. approved.

WIRING AND HOOKUP (Only by a qualified electrician/installer!)

120 VAC

Be sure your main power (120vac) is OFF before attempting hookup. The 120 volts AC supply should be terminated to the wires in top of the 4"x4" tube at the top of the chassis. Connect the 120 VAC to BLACK wire, Neutral to the WHITE wire and Ground the GREEN wire. **Warning- Do not connect any 120 VAC wires directly to the terminal strips on the electronic control board.** Only U.L. approved 14 AWG (or larger) 600 volt insulated wire should be used. A separate UL approved 10 amp circuit breaker should be used for each MEGA-ARM operator. **BATTERIES MUST BE INSTALLED AFTER 120VAC POWER IS TURNED ON.** See BATTERY at page 3 and 120 VAC wiring on page 4.

INPUT COMMANDS

Control wire connections at low voltage terminal strip will be at the top of the electronic control board. Make connections to the appropriate points for the desired operation. Wires should be U.L. approved 600 volt rated and at least 18 awg. They are to be routed through the upper grommet in chassis to avoid chafing. All external control devices must have normally open dry contacts. **DO NOT CONNECT ANY DEVICE WHICH WOULD DELIVER ANY VOLTAGE OF ANY KIND TO THESE TERMINALS.**

Terminals 9, 10, 11, 12 are the commons (0 VDC) used to activate the following inputs.

1, 2, 3 OPEN- These inputs will trigger gate open when pulsed or hold gate open with maintained contact. When released gate will close if closing timer is on or if close input is given.

4, AUXILIARY OPEN - Same as 1,2 and 3 with S2 switch 6 off. With S2 switch 6 on, this input will memorize multiple vehicles and not allow gate to close until the final vehicle in memory crosses the close loop. Use with laser scanners or card readers and (transmitters with timed anti-pass back). With S1 switch 5 on, this input becomes a momentary **pulse open, pulse close.**

NOTE: Insert a jumper across the JP2 terminal to allow the interlock feature (see page 5 & 13) to work with the multiple vehicle memory count selection, use the K1 relay to open the interlocked gate (S1-5 off, S2-6 on, jumper across JP2). This allows gate to store input counts via J5 #4 but not raise the arm until the interlocked slide or swing gate has fully opened.

5, SAFETY- This input is generally not used with the MEGA-ARM. If used its function is to make gate reverse and go back to the open position if it was closing. Input is disabled when gate is closed.

6, CLOSE- When used with a vehicle detector, it is recommended that the presence contacts (N.O. & C.) be used for the close input. This input will close gate after input is applied and then removed. It will stop the open cycle and reverse gate to close. (Example: Car crosses over close loop before arm reaches full open position- gate will reverse and close). (Note: The close input also acts as a safety-stop in that if gate is closing and a tailgater is sensed at the close input, the gate WILL STOP its closing motion and not continue to close until the close input is removed or gate is re-opened).

INPUT COMMANDS (Continued)

7, BACK-AWAY (FREE EXIT INPUT) This input is used as a free exit input to open gate. When input is active, gate will open and close immediately once input is removed. (EXAMPLE: Car pulls up to exit loop, gate opens; car "backs-away" from exit loop and gate closes).

8, SHAD- INTERLOCK (REDEFINED INPUT!!!) Used to monitor an auxiliary open limit switch of another operator in the same lane. Interlock with memory feature (v5.20 or higher) see page 13.

9, 10, 11, 12- COMMON- These are the commons (0 VDC) to be used to activate above inputs.

Note: Above inputs are tied to LED indicators to show input command activity.

ACCESSORY CONNECTIONS

These terminals will provide battery backed power to 24 VDC devices and are located at the bottom of the electronic control board at terminals 1 and 2. Terminal 1 is 24 VDC (+) and number 2 is 0 VDC (-). Peripheral CLASS 2 low voltage devices that require 24 VDC power maybe connected here (500 ma. maximum). EXAMPLE: Vehicle detector, radio receiver.

RELAY OUTPUT K1- (OPTION)

S1-6 off, S1-8 off, relay will fire (latch) when gate is not closed.

S1-6 on S1-8 off, relay will fire when arm is pushed up off of limit switch (use with slip clutch option). and fires relay when a tail-gate is detected by the close loop -ANTI TAIL-GATE ALARM

S1-6 off S1-8 on relay will pulse relay when arm reaches full open position.

S1-6 on S1-8 on relay will only pulse when input is given to J5 1,2,3 inputs. (see page 13).

BATTERY INSTALLATION

HOOKING UP BATTERY LEADS- ALWAYS HOOKUP AND TURN ON AC POWER **BEFORE** INSTALLING BATTERIES. After turning on AC power, install two new, fully charged 12 volt DC batteries on shelf next to motor. Connect red lead from operator to the positive (RED +) terminal of one battery and black lead from the operator to the (BLACK-) terminal of the OTHER battery. Place the supplied jumper between the remaining terminals of each battery if one is not already in place. See diagram. (USE YUASA BRAND PN#NP7-12)

WARNING-DO NOT RUN OPERATOR WITHOUT INSTALLING THE BATTERIES

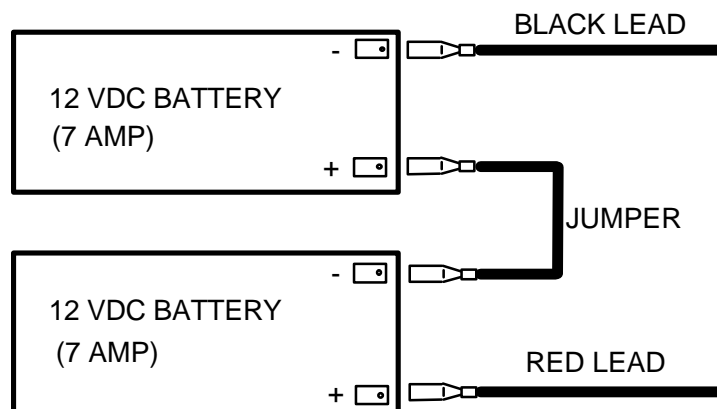

Failure to install batteries correctly WILL cause damage and WILL not be covered by warranty.

120 VAC POWER CONNECTION

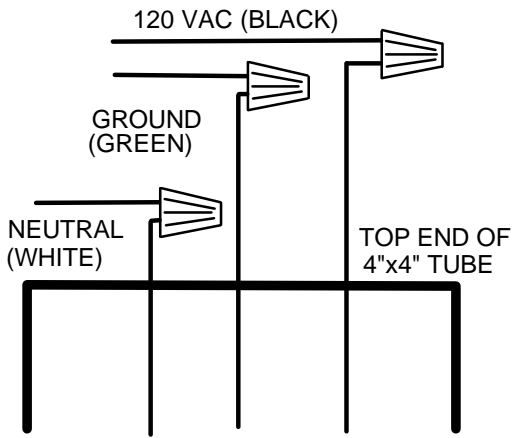

120 VAC CONNECTIONS ARE TO BE MADE IN TOP OF 4"x4" TUBE (POST). ONLY USE UL-LISTED 600 V WIRE INSIDE TUBE.

MASTER SLAVE WIRING

Master-slave wire hook up.

STEP 1- In a master/slave configuration, either unit can be the master. Choose one unit to be the master and then direct all control wiring to it (also install vehicle detector and receivers in it).

STEP 2- At the MASTER, any input (at J5) with control (detectors, receivers, keypads, timers, etc...) wires to it must also be run to the same terminals of the slave. Along with these control wires, both operators MUST share a common ground connection from chassis to chassis (or from common to common , i.e. master gate J5 terminal #12 to slave gate J5 terminal #12)

EXAMPLE: If only open and close are used at master then three wires will run between gates.

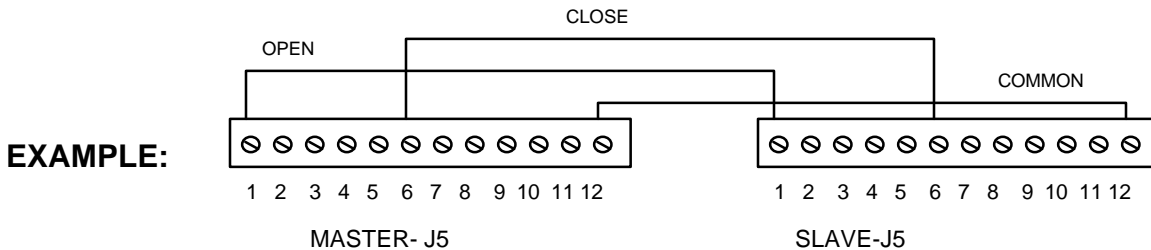

STEP 3- If it is required that if one gate senses an obstruction, the other reverses also, then 3 additional wires must be run between the master **J3** and slave **J3** as shown below. These connections are for transmitting IRD (obstruction signals) between both units. This will allow the master or slave to inform the other that a closing obstruction has occurred and for it to also reverse and open. **SET** switches on **S2, 1-8** the same on both gates.

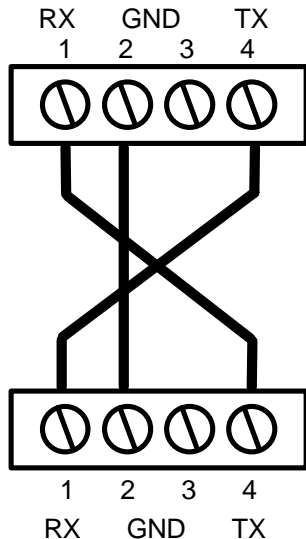

MASTER - J3

IRD - OBSTRUCTION SIGNAL CONNECTIONS

THE CONNECTIONS TO THE LEFT MUST BE DONE IN ORDER FOR GATE IRD'S TO WORK CORRECTLY. TERMINAL 1 OF MASTER MUST GO TO TERMINAL 4 OF SLAVE AND TERMINAL 1 OF SLAVE MUST GO TO TERMINAL 4 OF MASTER. TERMINAL 2 OF MASTER WILL GO TO TERMINAL 2 OF SLAVE.

SLAVE - J3

TIMERS AND MODE SECTIONS-(S1 and S2)

FULL SPEED RUN TIMER- SWITCH PACK S1 (1-4) With all switches off the default is approximately 1.5 seconds. Changing settings will adjust fast run timer by 1/8 second increments. (Example: 2 on equals 1/4 seconds, 4 on equals 1 second. 2 and 4 on equals 1.25 seconds)

1/8ths SECONDS 1 2 4 8

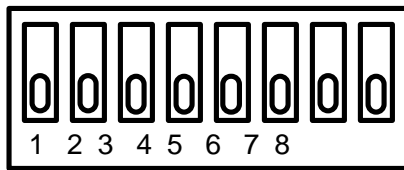

SHOWS DEFAULT SETTINGS

FAST RUN TIMER 1-4 | MODE SELECTION 5-8

MODE SELECTIONS- SWITCH PACK S1 (5-8)

SWITCH - 5. ON -Will allow J5 input 4 to operate as a pulse open/pulse close function.

SWITCH - 6. ON -Will fire relay if gate is pushed UP from closed limit, used with clutch option. Also ANTI TAIL-GATE ALARM, if tail gating is detected by close loop, K1 relay will fire. When using clutch option, turning on S1-6 & S2-7, gate will close by timer whenever forced up.

SWITCH - 7. USED TO ENABLE ARM TO WORK IN REVERSE DIRECTION, SEE PAGE 11.

SWITCH - 8. Off will make K1 relay activate during open cycle(use with buzzers, counters, etc..) On will pulse K1 relay when OPEN LIMIT (OLS) is reached (activates a swing or slide gate its lane). (SEE ALSO PAGE 3 - **RELAY OUT PUT-K1.**

CLOSE TIMER- SWITCH PACK S2 (1-5)

On the MEGA-ARM the switches 1-5 on S2 are for the closing time delay to select the period of time that the gate stays open after the obstruction sensor has reversed and re-opened the arm or if the S2-7 timer to close is turned on. The default will keep the gate up for 4 seconds to allow the vehicle to be moved from the gate arm path. Changing settings 1 - 5 will increase or decrease this hold open time. The default of **3 ON and 1,2,4,5 OFF** will provide a 4 second close time delay .

SECONDS----- 1 2 4 8 16

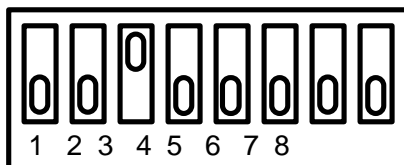

SHOWS DEFAULT SETTINGS

CLOSE TIMER 1-5 | MODE SELECTION 6-8

MODE SELECTIONS- SWITCH PACK S2 (6-8)

SWITCH - 6. INPUT MEMORY. Activates multiple vehicle memory at aux input terminal #4 on J5.

SWITCH - 7 AUTO CLOSE TIMER. Default is **OFF**. On will close gate by timer when all inputs are cleared. Time is set by using S2 1-5 switches (WARNING-Special care should be used to avoid arm from closing on cars. Use safety loops, stop loops, photo beams and a long enough time delay) (Note: Can be used with multiple vehicle memory buffer to allow gate to close and reset count memory to zero. When using clutch option, turning on S1-6 & S2-7, gate will close by timer whenever forced up.

SWITCH - 8 AUTO OPEN ON POWER FAILURE. When switch number 8 is in the **ON** position, the operator will automatically open the gate approximately 15 seconds after the loss of power. Once power is restored the operator will resume normal operation after the first car passes closing loop or if close timer S2-7 in turned on (It is recommended to allow the gate to close by loop, not by timer).

ADJUSTMENTS

INSTANT REVERSE DEVICE (IRD)

The reverse device is an internal circuit that continuously monitors the motors current for increased draw. Turning the IRD1 right (CW more sensitive), or left (CCW less sensitive) in small increments will allow sensitivity adjustments (IF ARM DOES NOT REVERSE, DO NOT CONTINUE TO FORCE). The obstruction that you apply should STOP the arm. Adjust sensitivity so that consistent reversal occurs . If the gate stops while opening then the **IRD** is TOO sensitive. Some slight adjustment either way may be needed in order that the gate only reverses when obstructed. If gate is obstructed while closing, gate will reverse to the open position, time out (using the time delay set at S-2 switches 1-5) and then close. If gate is opening when obstructed, gate will stop its open travel, then will time out and close using the same delay set at S-2. If S-2 switch number 8 is off (you have programmed the unit to **NOT AUTO RAISE** when power fails) then recheck your adjustments with AC power off to be sure proper operation will be maintained.

NOTE- INSTANT REVERSE DEVICE (IRD) SHOULD BE TESTED MONTHLY TO INSURE PROPER OPERATION. IF ADJUSTMENTS ARE REQUIRED, REFER TO ABOVE PARAGRAPH. ADJUSTMENTS TO BE DONE BY QUALIFIED SERVICE PERSONS ONLY.

GATE ARM INSTALLATION AND LEVELING

Install arm in gate arm bracket by lining up holes in arm with the slotted holes in bracket. Insert the bolts through the arm and through the bracket. Next install the flat washers then the nylon nuts. (It is recommended the only nylon nuts be used to attach arms). The magnetic limit cam is pre-adjusted for near proper arm travel, however if leveling of the arm is required this can be done through adjustment to the magnetic cam arm. Note that during these adjustments the arm only travels approximately 85 to 89 degrees for its full motion. Always adjust for a level arm in the **HORIZONTAL POSITION**. There is a small set screw in the side of the cam arm which can be loosened to allow the cam arm magnet to reach the close limit sensor (located on back of controller, H2) earlier or later in its travel. Continue to open and close the gate while adjusting until a satisfactory horizontal stopping point can be maintained. Afterwards re-secure set screw in cam arm. (Note: In some cases additional adjustments may be required after the belt wears in). When stopping in the open position, the arm will stop just before the full vertical position.

NOTICE: TO PREVENT ENTRAPMENT, ALLOW FOR TWO (2) FEET MINIMUM CLEARANCE PAST END OF ARM WHEN IN DOWN POSITION.

SHEAR PIN REPLACEMENT

If gate arm is vandalized and the tapered pin in the output shaft has been sheared, it must be replaced correctly and with the right pin type. Replacement must be done by always punching out the pin (or pieces) from the small end only. If drilling is required, **DO NOT DAMAGE THE SHAFT**, use a drill bit smaller than the small hole size of the pin. (Correct pin is a 2" pin with a number 6 taper only)

NEVER USE A BOLT AS A TEMPORARY FIX, THIS WILL DAMAGE THE SHAFT AND COLLAR

- 1) Use **S-3** to rotate bracket to up position
- 2) Turn off AC power and disconnect batteries
- 3) Remove gate arm bracket and pieces in collar
- 4) Drive out pin pieces with hammer and punch
(Solid sharp blows are better than light ones)
- 5) Reinstall gate arm bracket
- 6) Lightly oil the new pin then insert into collar small end first.
- 7) Fully seat pin in shaft by taping on large end
- 8) Reinstall the arm if required
- 9) Turn on AC power and connect batteries
- 10) Turn off **S-3** to put gate into operation

TROUBLE SHOOTING AND MAINTENANCE PROCEDURES

WARNING - DISCONNECT BATTERIES AND AC POWER BEFORE SERVICING ANY MECHANICAL OR MOVING COMPONENTS!!!!

BATTERY CHECKOUT- When the batteries become weak the gate will begin to run noticeably slower. (Note: Batteries should only be checked when you are sure they have had adequate time to fully charge). Turn off the AC power and run gate for 5 to 10 cycles while observing low battery indicator LED D12. If LED 12 comes ON, batteries are too weak to function properly. If LED 12 does not light, then voltage should be checked as they still maybe near failure. Correct voltage is approximately 24.5VDC. (Note: If LED D12 does light, gate will open to conserve batteries in this test or in a real power loss, even if mode switch 8 on S2 is off). Return of AC power will clear low battery indicator. Correct charge voltage is 27.5 VDC with batteries not connected (adjustment is at R63).

GATE WILL NOT CLOSE

- 1) Check for any active inputs, AC power loss, AC power switch is off or weak batteries.
- 2) Check that batteries are connected properly.
- 3) Is switch S-3 in on position (this is manual open switch).
- 4) Check for S-2 switch number 8 is in on position and if AC power is lost, see LED D14.
- 5) Check LED D12, if lit and AC power is off, then batteries needs to be charged or replaced.

GATE WILL NOT OPEN

- 1) Check for AC power loss at D14 (check AC power switch) and that batteries are fully charged.
- 2) Check fuses and if inputs are wired correctly, test S-3 manual open switch.

GATE DEAD, NO OPERATION

- 1) Check LED D14 for AC power indication and check AC power switch is on.
- 2) Check LED D11 for Heart Beat pulses, if none and D14 (AC) & D5 (Brake) are on, then gate has repeatedly sensed obstructions. Clear obstruction then clear with next new input.
- 3) IRD (D2) LED is flashing, MRT has expired. H1, H2 (Hall sensors) and clearance to magnet on cam ***MUST*** be check for intermittent activation, failure to rectify may result in malfunctions. (MRT is **Maximum Run Timer** that disables the gate if the magnet does not reach H1 or H2). Reset the AC and battery power to clear this once you have rectified the problem.

FUSE(S) ARE BLOWN, F-3 (10 AMP AC) AND / OR F-4 (15 AMP DC)

- 1) Check for shorts in wiring. If F-3 AC fuse is blown then batteries may also be weak or dead.
"Warning- For Continued Protection Against Fire,
Replace Only With The Same Type And Rating Of Fuse".

GATE CLOSSES THEN REVERSES

- 1) See page 6 for IRD adjustments also check for obstacles in gate travel, trees etc.....
- 2) Charge voltage to batteries too low, adjust at **R63**. With batteries disconnected set to 27.5.

IRD OBSTRUCTION SIGNAL TO OTHER GATE NOT WORKING CORRECTLY

- 1) Remove connector at J3, obstruct arm, LED D13 should go off for a few seconds. This indicates signal was transmitted. Be sure gates share a common ground (See master slave pg. 4)

GENERAL SERVICE

- 1) Belt loose or needs replacement, adjust with 4 bolts that support motor to allow 1/4 inch play.
- 2) Charge voltage for batteries should be 27.5 VDC with batteries disconnected. (set at R63)
 - 3) Replace batteries with **Yuasa, pn# NP7-12**, 7 amp hour 12vdc sealed lead / acid type.

SAMPLE CONFIGURATIONS

FREE EXIT ON VEHICLE APPROACH:

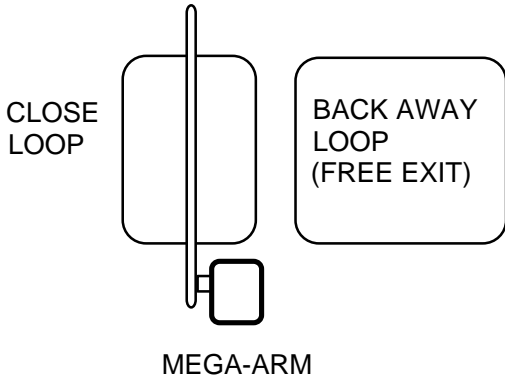

GATE WILL OPEN WHEN SENSED BY EXIT LOOP AND THEN CLOSE ONCE THE CLOSE LOOP IS CLEARED. IF THE VEHICLE PULLS UP TO THE EXIT LOOP AND THEN BACKS AWAY IT WILL CLOSE.
(SPACE BETWEEN LOOPS WILL BE 4' TO 10')

TERMINAL # 7 IS BACKAWAY (FREE EXIT).
 TERMINAL # 6 IS CLOSE INPUT.

ENTRY WITH ACCESS CONTROL DEVICE:

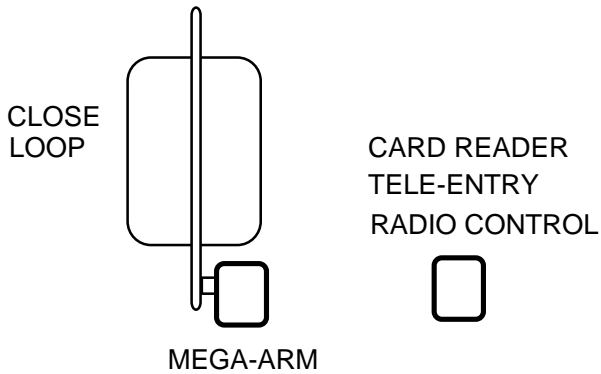

GATE WILL OPEN WHEN ACTIVATED BY AN ACCESS CONTROL DEVICE. WHEN VEHICLE PASSES AND CLEARS CLOSE LOOP, GATE WILL CLOSE.

NOTE: IF A SECOND VEHICLE TAIL-GATES AND IS SENSED AT THE CLOSE LOOP, GATE WILL STOP ITS CLOSING MOTION UNTIL LOOP IS CLEARED AGAIN.

TERMINAL # 6 IS CLOSE INPUT.
 TERMINAL # 1,2,3 ARE OPEN INPUTS.

DUAL DIRECTION AS ENTRY OR FREE EXIT:

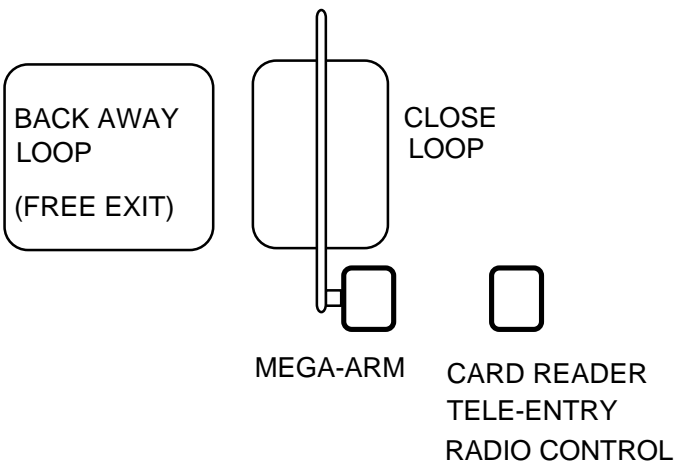

DUAL DIRECTION IS A COMBINATION OF BOTH OF THE ABOVE CONFIGURATIONS TO PROVIDE THE ABILITY FOR TRAFFIC TO ENTER OR EXIT IN THE SAME LANE.

(SPACE BETWEEN LOOPS WILL BE 4' TO 10')

RECOMMENDATION 1: If vehicle detectors are used to open or close the gate, use of the presence contacts are recommended. Using the pulse contacts will **REDUCE** the gates safe operation.

RECOMMENDATION 2: If closing timer is to be used, use **ONLY** on a dedicated free exit.

RECOMMENDATION 3: Close loop must be centered under gate arm.

CONTROL BOARD LAYOUT

BOARD REV 2.0 (2/98)

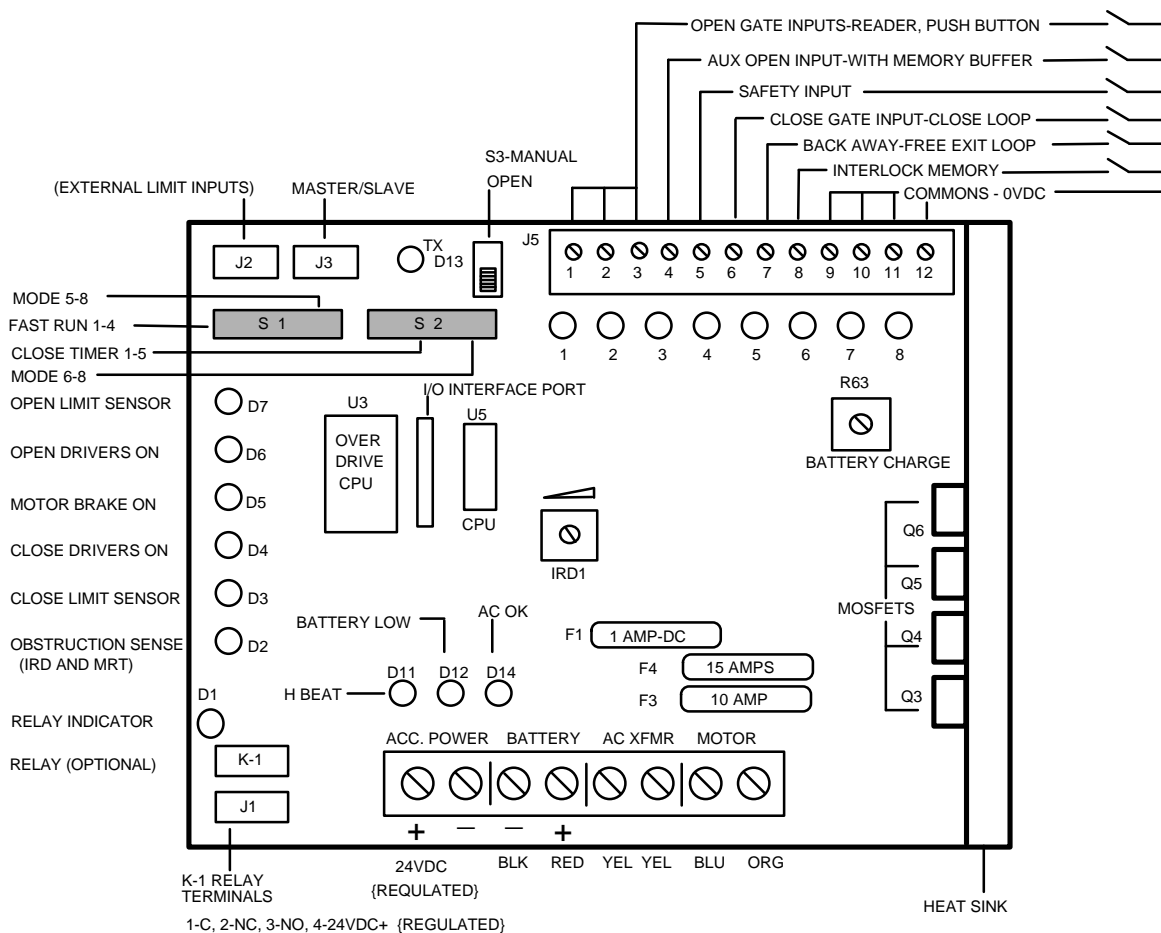

ACCESSORY POWER IS 24VDC REGULATED RATED AT 500 ma. [1/2 AMP]
 {POWER AT ACCESSORY+ AND AT RELAY PIN-4+ IS FUSED AT F1 WITH A 1 AMP FAST-BLO FUSE}

NOTE: J5 #8 IS NOW THE INTERLOCK WITH MEMORY INPUT (SEE PAGE 13)

D11- HEART BEAT- SHOWS THAT PROCESSOR AND PROGRAM ROUTINE ARE RUNNING PROPERLY

D12- BATTERY STATUS- SEE DIAGNOSTIC PROCEDURES

D14- AC POWER INDICATOR- SHOWS THAT AC POWER IS PRESENT

S3- MANUAL OPEN- TO ALLOW GATE TO BE OPENED OR CLOSED DURING SERVICE OF UNIT.

F1- 1 AMP FAST BLO FUSE (5mmX20mm). MAXIMUM CONTINUOUS DRAW IS 1/2 AMP. (U.L. FUSE ONLY)

F3- 10 AMP ATO TYPE FUSE FOR 24VAC INPUT POWER. (U.L. LISTED FUSE ONLY)

F4- 15 AMP ATO TYPE FUSE FOR 24VDC BATTERY INPUT POWER. (U.L. LISTED FUSE ONLY)

MEGA-ARM PARTS LIST

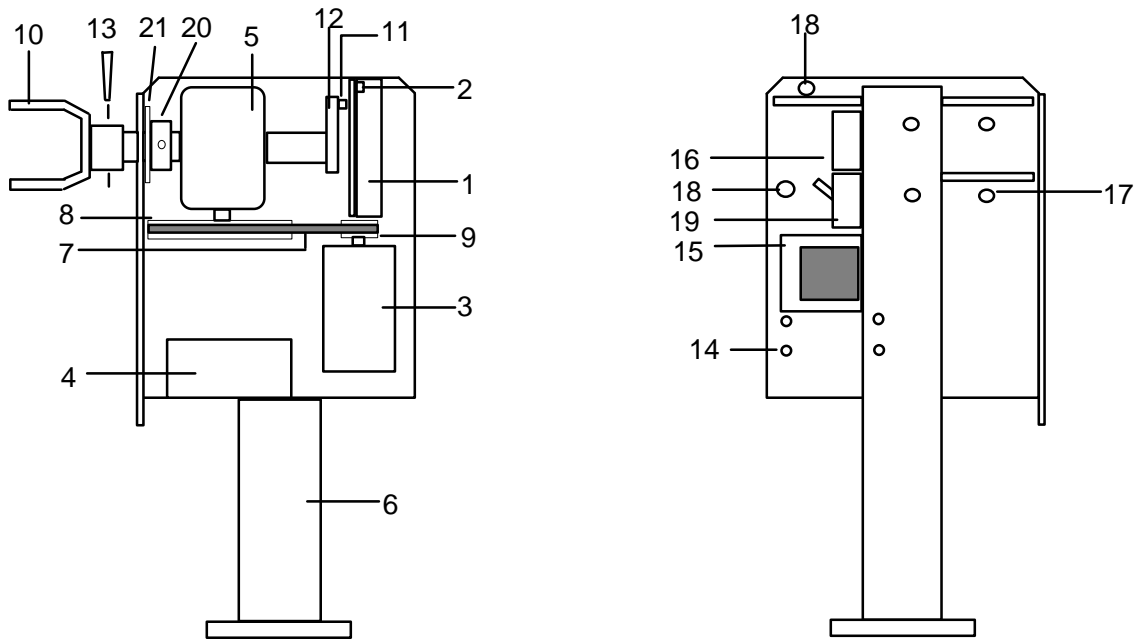

ITEM	PN	DESCRIPTION
1	MA-001	CONTROLLER-CPU
2	MA-002	REMOVABLE CONNECTOR
3	MA-003	DC MOTOR - 24 VDC
4	MA-004	12VDC 7AH BATTERY-2 REQUIRED (NOT INCLUDED)
5	MA-005	GEAR REDUCER 60:1
6	MA-006	ALUMINUM CHASSIS
7	MA-007	DRIVE BELT
8	MA-008	REDUCER PULLEY
9	MA-009	MOTOR PULLEY
10	MA-010	GATE ARM BRACKET
11	MA-011	MAGNET
12	MA-012	CAM ARM
13	MA-013	SHEAR PIN
14	MA-014	BOLT & NUT (4) MOTOR
15	MA-015	TRANSFORMER (110 / 220 VAC-24VAC)
16	MA-016	MAIN POWER CONNECTION BOX
17	MA-017	BOLT & NUT (4) REDUCER
18	MA-018	GROMMET (2)
19	MA-019	117 VAC ON-OFF SWITCH
*	MA-020	UNIT COVER
*	MA-021	NYLON ARM NUTS (2)
*	MA-022	ARM BOLTS (2)
*	MA-023	GATE ARM-12 FT
20	MA-036	COLLAR
21	MA-037	NYLON WASHER

(*) PARTS NOT SHOWN

PARTS SHIPPED

- 1 MEGA-ARM OPERATOR
- 1 CONTROLLER CPU
- 1 UNIT COVER
- 1 INSTALLATION AND SERVICE MANUAL
- 2 ARM BOLTS WITH WASHERS
- 10 NYLON NUTS

UNIT ALSO REQUIRES (2) SEALED 12 VDC 7 AMP HR BATTERIES- NOT INCLUDED

REVERSING ARM DIRECTION

THE MEGA ARM ALLOWS FOR THE "HANDING" OR REVERSING OF THE ARMS DIRECTION OF MOVEMENT IN RELATION TO THE UNITS NORMAL OPERATION. THIS ALLOWS FOR MOUNTING IN TIGHT PLACES OR WHEN IT IS DESIRED TO HAVE THE ARM , WHEN ACROSS THE DRIVE WAY, TO BE IN FRONT OF THE UNIT OR BEHIND THE UNIT WHEN VIEWED FROM THE TRAFFIC FLOW DIRECTION.

WARNING- POWER MUST BE OFF AND NO ARM INSTALLED BEFORE MAKING THESE CHANGES

- STEP 1) ONLY UNITS WITH SOFTWARE VERSIONS v4.14 OR HIGHER HAVE THIS CAPABILITY. BEFORE POWER UP SWITCH BANK S1 SWITCH #7 MUST BE ON.
- STEP 2) NEXT THE MOTOR WIRES ON THE CONTROL BOARD MUST BE REVERSED. AT J4 ON THE BOTTOM OF PCB, THE LAST 2 WIRES ON THE RIGHT (J4-7, J4-8) NORMALLY ARE BLUE THEN ORANGE. THEY MUST BE REVERSE TO BE (J4-7) ORANGE THEN (J4-8) BLUE.
- STEP 3) AFTER COMPLETING THE STEPS ABOVE, THE CAM ARM WHICH ADJUSTS THE LIMITING POINTS OF THE ARMS TRAVEL MUST BE TURNED 90 DEGREES TO THE LEFT WHEN VIEWED WHILE STANDING IN FRONT OF THE CONTROL BOARD (CAM ARM NOW POINTS IN THE DIRECTION OF THE ARM AND IS LEVEL WITH MOUNT BRACKET, NOTE THE SMALL LIMIT SENSORS ON THE BACK OF THE PCB).
- STEP 4) NOW CHECK TO MAKE SURE THAT S1 #7 IS ON, MOTOR WIRES ARE REVERSED, THE CAM IS ADJUSTED AND THAT THE MANUAL OPEN CLOSE SWITCH (S3) IS SET TO CLOSE. NEXT TURN ON THE AC POWER AND CONNECT THE BATTERIES. NOW RUN THE GATE OPEN AND CLOSE WITH THE S3 MANUAL SWITCH MAKING SURE THAT THE MECHANISM TRAVELS IN THE PROPER 90 DEGREES DESIRED. ONCE YOU ARE TOTALLY SURE YOU HAVE THE CORRECT OPERATION YOU CAN INSTALL THE ARM.

INSTALLATION NOTE: ARMS LONGER THAN 12 FEET MUST USE THE PROPER COUNTER WEIGHT

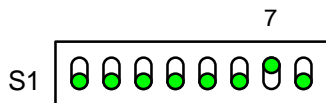
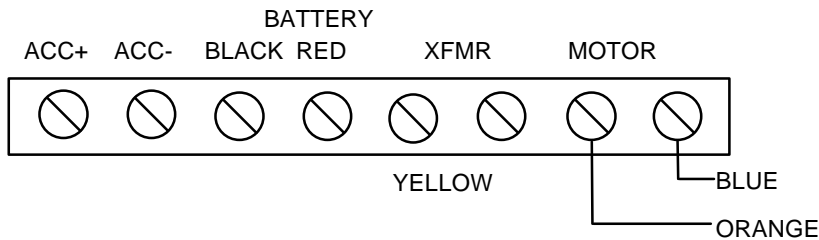
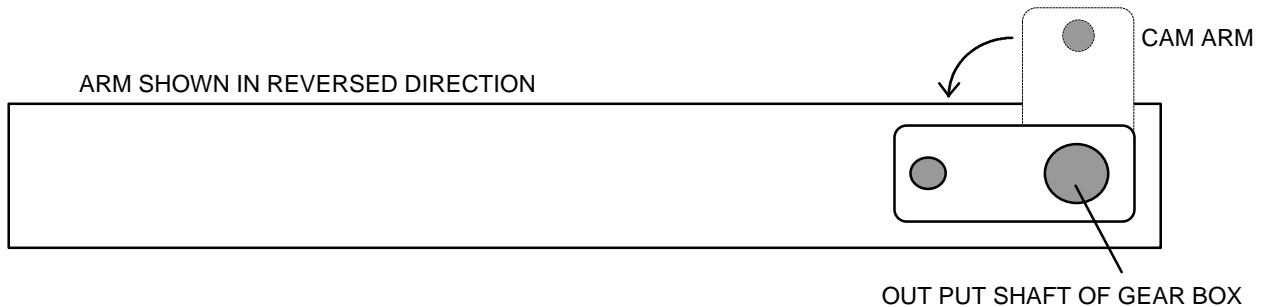

S1, #7 TO BE TURNED ON BEFORE POWER UP TO ENABLE REVERSE OF ARM

INTERLOCK WITH MEMORY FEATURE

INTERLOCK WITH OTHER OPERATORS: (REQUIRES THE K1 RELAY OPTION)

VERSIONS 5.20 OR GREATER NOW HAVE THE ABILITY TO ALLOW THE MEGA-ARM TO MONITOR FOR THE FULL OPEN POSITION OF A SLIDE, SWING, VERTICAL PIVOT, ROLL UP OR OVERHEAD OPERATOR AS WELL AS THE DOWN POSITION OF MOTORIZED TRAFFIC TEETH (MTC-31) AND RAISE THE ARM ONCE FULLY OPEN.

This new feature will allow a logical interface between the MEGA ARM barrier gate and a swing, slide, etc... gate operator (or MTC-31). All that is required is 4 wires between the Mega Arm barrier gate and the other operator. It will be necessary to have one set of dedicated/isolated dry contacts-{C. & N.C.} COMMON & NORMALLY CLOSED be available at the other operators OPEN LIMIT SWITCH. Most units will require that this EXTRA limit switch be added to their open limit switch assembly.

OPERATION: A one second pulse from access control device to the MEGA ARM will energize its K1 relay sending an open signal to the other operator causing it to open, however, the MEGA ARM's boom will not raise yet. When the other operator reaches its full open limit switch, this will open the COMMON & NORMALLY CLOSED contact on the EXTRA open limit switch. This will allow the original signal from your access control device (that was stored in memory) to now raise the gate arm. As long as the other operator is in the full open position, any additional open pulse sent will in turn energize the MEGA ARM's K1 relay to send another open signal to the other operator as well as cause the arm to raise again if it has closed via a car crossing the MEGA ARM's close loop.

WIRING: Run 2 wires from the other operators isolated common & normally closed contacts of its open limit switch to the MEGA ARM J5#8 and one of the commons J5 , #9-12. Next run 2 wires from the MEGA ARMs K1 relay (common & normally open) to the other operators common and open input. (WARNING: max of 30 VOLTS @ .5 AMPS THROUGH RELAY). J5 #8 was the unused SHADOW LOOP input on the MEGA ARM. Note: A separate open device (24 hour timer, toggle switch) can be run to the other operator to control it without raising the gate arm. Tampering with the other operators safety loops, safety edges and reverse sensors **WILL NOT** cause the arm to raise if one tripped. The arm will only raise if an intended open signal was sent to the MEGA ARM.

NOTE: FOR MOTORIZED TEETH, VERTICAL PIVOT OR OVERHEAD OPERATOR, LEAVE S1-6, S1-8 OFF (THIS WILL KEEP THE K1 RELAY **LATCHED** UNTIL THE ARM REACHES THE DOWN POSITION. THIS WILL KEEP THE OTHER GATE OPERATOR **LOCKED OPEN** OR TEETH **LOCKED DOWN** UNTIL THE ARM CLOSES COMPLETELY). NOTE: IN THIS MODE IF THE ARM SENSES AN IMPACT, THE K1 RELAY WILL STAY ENERGIZED HOLDING **OPEN** (OR TEETH DOWN) THE OTHER OPERATOR UNTIL THE ARM TIMES OUT AND CLOSES.

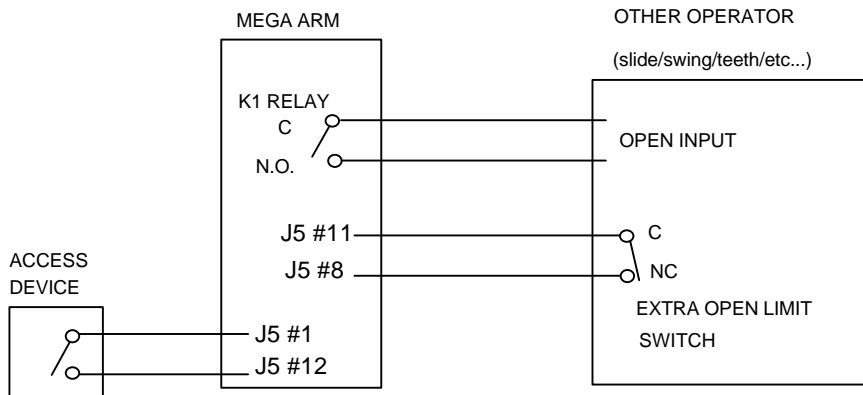

S1, 6 & 8 (ON) = K1 RELAY PULSE ONLY. S1, 6 & 8 (OFF) = K1 RELAY LATCH ONLY.

INTER-LOCK TWO MEGA ARMS WITH "MEMORY": REQUIRES THE K1 RELAY OPTION

NOTE: (5.20 or greater) can be used when you have two entry gates that you want to **INTER-LOCK** with each other. This is when you can only have **ONE** gate raised at a time (bottle neck or gates at a cross street). In this case, which ever one raises first will get first priority, while if the other gets an open signal, it will be **HELD IN MEMORY**, then raise once the first gate closes. This will work if either gate has a telephone entry unit or access device (AVI ,prox , etc...). Connect the K1 relay C & N.O. of each gate to the SHADOW LOOP J5 #8 input & common of the other . (Leave S1-6 & 8 OFF to allow relay to stay latched).

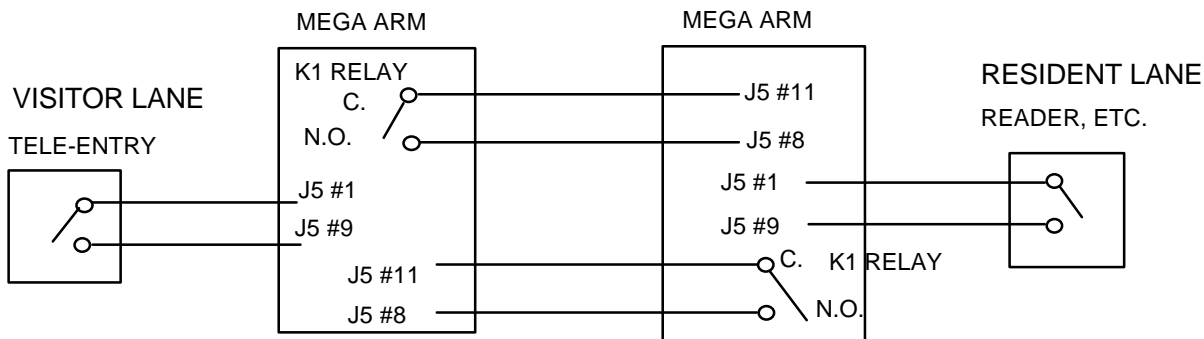

(You must read, understand and agree with all items in the limited warranty)

LIMITED WARRANTY

DC SOLUTIONS, INC. Warrants the **MEGA-ARM** to be free of defects in workmanship and materials for a period of 1 year for electronics and mechanical components and 5 years on the cover and chassis for perforation due to corrosion. Warranty will begin from the date of purchase.

DC Solutions, inc. reserves the right of final determination as to the existence and causes of any defect or failure. Any part or parts found to be defective and are returned to DC Solutions within the warranty period, shall at our option be repaired or replaced free of charge F.O.B. the factory.

The warranty will not apply the following circumstances which are considered beyond our control. Mis-use, vandalism, accident, neglect, unauthorized repairs or modifications, acts of God (lightning, floods, insect damage, etc...), power surges, units subjected to corrosive environments, incorrect installation or application, the batteries or incorrect battery installation , operation without or failure to use correct battery type, damage to arm bracket and / or gear reducer due to use of incorrect arm.

The warranty set forth above is entirely exclusive and no other warranty whether written or oral, is expressed or implied. DC Solutions, inc. specifically disclaims any and all implied warranties, merchantability or fitness for a particular purpose. It is the purchasers sole and exclusive responsibility to determine whether or not the equipment will be suitable for a particular purpose. In no event shall DC Solutions, inc. be held liable for direct, indirect, incidental, special, consequential damages or loss of profits whether based on contract, tort, or any other legal theory during the course of the warranty or at any time there after. The installer and/or end user agree to assume all responsibility for all liability in use of this product, releasing DC SOLUTIONS, INC of all liability.

WARNING!

MEGA ARM NOT FOR USE WITH MOTOR CYCLES, BICYCLES OR PEDESTRIANS.

YOU MUST PROVIDE APPROPRIATE SIGNAGE BEFORE ACTIVATING THE UNIT.

NEVER ALLOW CHILDREN TO PLAY NEAR OR OPERATE AUTOMATIC GATES.

IN ORDER TO INSTALL AND USE THE MEGA ARM, YOU MUST UNDERSTAND AND BE IN FULL UNCONDITIONAL AGREEMENT WITH ALL STIPULATIONS OUTLINED ABOVE. IF YOU ARE NOT IN FULL AGREEMENT, DO NOT PUT UNIT INTO OPERATION. IF OPERATOR IS PUT INTO OPERATION THIS WILL BE CONFIRMATION THAT YOU ARE IN FULL UNCONDITIONAL AGREEMENT WITH THE ALL OF THE ABOVE STIPULATIONS.

Materials, components, features and specifications are subject to change without notice.

WARRANTY REGISTRATION

MAIL OR FAX THIS PORTION TO DC SOLUTIONS TO CONFIRM YOUR WARRANTY

NAME OF INSTALLING DEALER _____

NAME OF CUSTOMER _____

ADDRESS _____

CITY _____ STATE _____ ZIP CODE _____

MODEL _____ SERIAL NUMBER _____

EXPECTED CYCLES PER DAY _____ NUMBER OF HOMES OR APARTMENTS _____

CONFIGURED AS A 1) VISITOR ENTRANCE _____ 2) RESIDENT ENTRANCE _____

3) MAIN ENTRANCE _____ 4) EXIT _____ 5) OTHER _____ (EXPLAIN) _____