



Owner's Manual

Series 1600 Barrier Gate Operators

DoorKing, Inc.
120 Glasgow Avenue
Inglewood, California 90301
U.S.A.
Phone: 310-645-0023
Fax: 310-641-1586
www.doorking.com

Use this manual with the following models only.

Models 1601-080, 1601-081, 1602-080, 1602-081 with circuit board 1601-010 REV V or higher.

NOTE: Models 1601-081, 1601-088 and 1602-081 will have a supplemental manual (P/N 2340-065) that describes the operation and setup of the optional battery backup system available with these units, and provides additional wiring information for these units.

DoorKing, Inc. reserves the right to make changes in the products described in this manual without notice and without obligation of DoorKing, Inc. to notify any persons of any such revisions or changes. Additionally, DoorKing, Inc. makes no representations or warranties with respect to this manual. This manual is copyrighted, all rights reserved. No portion of this manual may be copied, reproduced, translated, or reduced to any electronic medium without prior written consent from DoorKing, Inc.

IMPORTANT NOTICES

Vehicular gate systems provide convenience to their users and limit vehicular traffic onto your property. These systems can produce high levels of force, therefore it is important that you are aware of possible hazards associated with your gate operating system. These hazards may include pinch points, entrapment, absence of controlled pedestrian access or traffic backup.

Be sure that the installer has instructed you on the proper operation of the gate and gate operator system. Be sure that the installer has trained you about the basic functions of the reversing systems associated with your gate operating system and how to test them. These include reversing loops, inherent reversing system, and may include electric edges, photo electric cells, or other external devices.

- This Owner's Manual is your property. Keep it in a safe place for future reference.
- The speed limit for vehicular traffic through the gate area is 5 MPH. Install speed bumps and signs to keep vehicular traffic from speeding through the gate area. Failure to adhere to posted speed limits can result in damage to the gate, gate operator, and to the vehicle.
- Be sure that all residents are familiar with the proper use of the gate and gate operator. Be sure that all residents are familiar with the possible hazards associated with the gate system.
- Be sure that all warning signs are permanently installed on both sides of the gate in an area where they are fully visible to traffic.
- It is your responsibility to periodically check all reversing devices. If any of these devices are observed to function improperly, remove the operator from service immediately and contact your installing or servicing dealer.
- Follow the recommended maintenance schedule.
- Do not allow children to play in the area of the operator or to play with any gate operating device.
- Be sure that all activating devices are installed a minimum distance of 10 feet away from the gate and gate operator, or in such a way that a person cannot touch the gate or gate operator while using the activating device. If activating devices are installed in violation of these restrictions, immediately remove the gate operator from service and contact your installing dealer.
- To remove the gate operator from service, operate the arm to the full up position and then shut off power to the operator at the service panel.

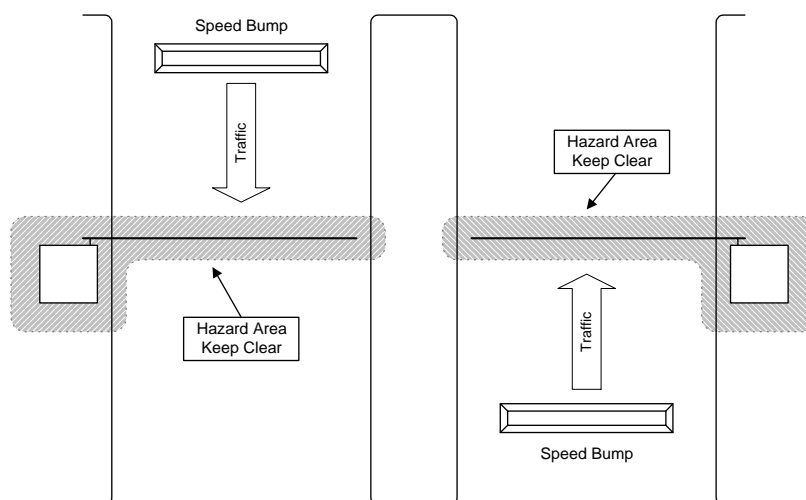

GLOSSARY

RESIDENTIAL VEHICULAR GATE OPERATOR-CLASS I - A vehicular gate operator (or system) intended for use in a home of one-to four single family dwelling, or garage or parking area associated therewith.

COMMERCIAL / GENERAL ACCESS VEHICULAR GATE OPERATOR-CLASS II - A vehicular gate operator (or system) intended for use in a commercial location or building such as a multi-family housing unit (five or more single family units), hotels, garages, retail store, or other building servicing the general public.

INDUSTRIAL / LIMITED ACCESS VEHICULAR GATE OPERATOR-CLASS III - A vehicular gate operator (or system) intended for use in an industrial location or building such as a factory or loading dock area or other locations not intended to service the general public.

RESTRICTED ACCESS VEHICULAR GATE OPERATOR-CLASS IV - A vehicular gate operator (or system) intended for use in a guarded industrial location or building such as an airport security area or other restricted access locations not servicing the general public, in which unauthorized access is prevented via supervision by security personnel.

VEHICULAR BARRIER (ARM) OPERATOR (OR SYSTEM) - An operator (or system) that controls a cantilever type device (or system) consisting of a mechanical arm or barrier that moves in a vertical arc, intended for vehicular traffic flow at entrances or exits to areas such as parking garages, lots or toll areas.

SYSTEM - In the context of these requirements, a system refers to a group of interacting devices intended to perform a common function.

WIRED CONTROL - A control implemented in a form of fixed physical interconnections between the control, the associated devices, and an operator to perform predetermined functions in response to input signals.

WIRELESS CONTROL - A control implemented in means other than fixed physical interconnections (such as radio waves or infrared beams) between the control, the associated devices, and an operator to perform predetermined functions in response to input signals.

INHERENT ENTRAPMENT SENSOR SYSTEM - An automatic sensor system which senses entrapment of a solid object and is incorporated as a permanent and integral part of the operator.

RESTRICTIONS AND WARNINGS

Install The Barrier Operator Only If:

- The operator is appropriate for the usage Class of the application.
- **The Model 1602 is designed for industrial applications only. The 1602 is not designed for use in heavy traffic applications such as gated communities or apartment complexes. It should not be used in PAMS applications to prevent tail-gating. Use the Model 1601 for these applications.**
- All exposed pinch points are eliminated or guarded.
- This operator is intended for installation only on barrier gates used to control vehicular traffic. Pedestrians must be provided with a separate access opening.
- The gate must be installed in a location so that sufficient clearance is provided between the gate and adjacent structures when opening and closing to reduce the risk of entrapment.
- Controls must be far enough from the gate so that the user is prevented from coming in contact with the gate while operating the controls. Outdoor or easily accessible controls should have a security feature to prevent unauthorized use.
- All warning signs and placards must be installed where visible in the area of the gate.

IMPORTANT SAFETY INSTRUCTIONS

WARNING - To reduce the risk of injury or death:

1. READ AND FOLLOW ALL INSTRUCTIONS.
2. Never let children operate or play with gate controls. Keep the remote control away from children.
3. Always keep people and objects away from gate. **NO ONE SHOULD CROSS THE PATH OF THE MOVING GATE.**
4. Test the operator monthly. The gate **MUST** reverse on contact with a rigid object or stop or reverse when an object activates the non-contact sensors. After adjusting the force or the limit of travel, retest the gate operator. Failure to adjust and retest the gate operator properly can increase the risk of injury or death.
5. **KEEP GATES PROPERLY MAINTAINED.** Read the owner's manual. Have a qualified service person make repairs to gate hardware.
6. The entrance is for vehicles only. Pedestrians must use separate entrance.
7. **SAVE THESE INSTRUCTIONS.**

TABLE OF CONTENTS

Section 1 – Installation

1.1	Specifications	9
1.2	Mounting Positions	10
1.3	Pad Construction	11
1.4	Operator Mounting.....	12
1.5	Arm Mounting Hardware Installation	13

Section 2 – Electrical

2.1	Conduits	15
2.2	High Voltage.....	16
2.3	Low Voltage Wiring	
2.3.1	Control Wiring	17
2.3.2	Master / Slave Control Wiring	18
2.3.3	PAMS Control Wiring	19
2.3.4	Gate Tracker™ Control Wiring.....	20
2.4	Loop Detector Wiring	
2.4.1	Entry Lane Application	22
2.4.2	Exit Lane Application.....	23
2.4.3	Ticket Spitter Application.....	24
2.4.4	Two Way Lane Application.....	25
2.4.5	Timer Down Application	26
2.5	Main Terminal Identification and Description	27

Section 3 – Adjustments

3.1	Circuit Board Adjustments	29
3.2	Switch Settings	30
3.3	Magnetic Limit Adjustment	32
3.4	Reverse Sensitivity Adjustment	33
3.5	Operator Testing.....	34

Section 4 – Arm and Accessory Installation

4.1	Arm Installation	
4.1.1	Direction Check.....	35
4.1.2	Arm Hub Installation.....	36
4.1.3	Arm Installation Model 1601.....	37
4.1.4	Wishbone Arm Installation Model 1602.....	38
4.2	Accessory Installation	
4.2.1	Reversing Edge.....	39
4.2.2	Heater Kit	40
4.2.3	Fan Kit	41

Section 5 – Maintenance and Troubleshooting

5.1 Maintenance Schedule43
5.2 Trouble Shooting44
5.3 Accessories45

SECTION 1 - INSTALLATION

Prior to beginning the installation of the barrier gate operator, we suggest that you become familiar with the instructions, illustrations, and wiring guidelines in this manual. This will help insure that your installation is performed in an efficient and professional manner.

The proper installation of the vehicular barrier gate operator is an extremely important and integral part of the overall access control system. Check all local building ordinances and building codes prior to installing this operator. Be sure your installation is in compliance with local codes.

1.1 SPECIFICATIONS

Class of Operation:	Class II, III, IV
Type of Gate:	Vehicular Barrier Gates Only
Horsepower:	1601 - 1/2 H.P., 1602 - 1 H.P.
Voltage / Phase:	120, 230, 460 VAC / Single Phase
Current:	1601 - 5.4 @ 120V; 2.7 @ 230V; 1.35 @ 460V 1602 - 14.0 @ 120V; 7.0 @ 230V; 3.5 @ 460V.
Max Arm Length:	1601 - 14 Ft. (Aluminum or wood arm), 12 Ft. (plastic arm)
Max Arm Length:	1602 - 20 Ft. (three piece wood arm only)
Cycles / Hr:	1601 - 500, 1602 - 60
Speed:	1601 - 90° in approximately 1.5 seconds 1602 - 90° in approximately 5 seconds

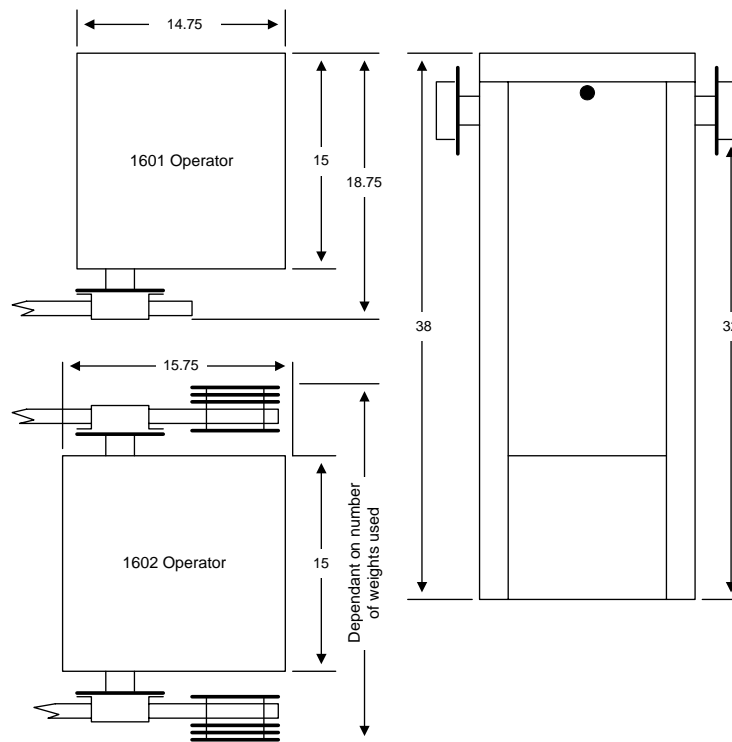

Figure 1

1.2 MOUNTING POSITION

The 1601 and 1602 operators are designed to be mounted in either a left hand or right hand mounting position. Care should be taken to be sure that the access door to the operator is opposite the traffic lane.

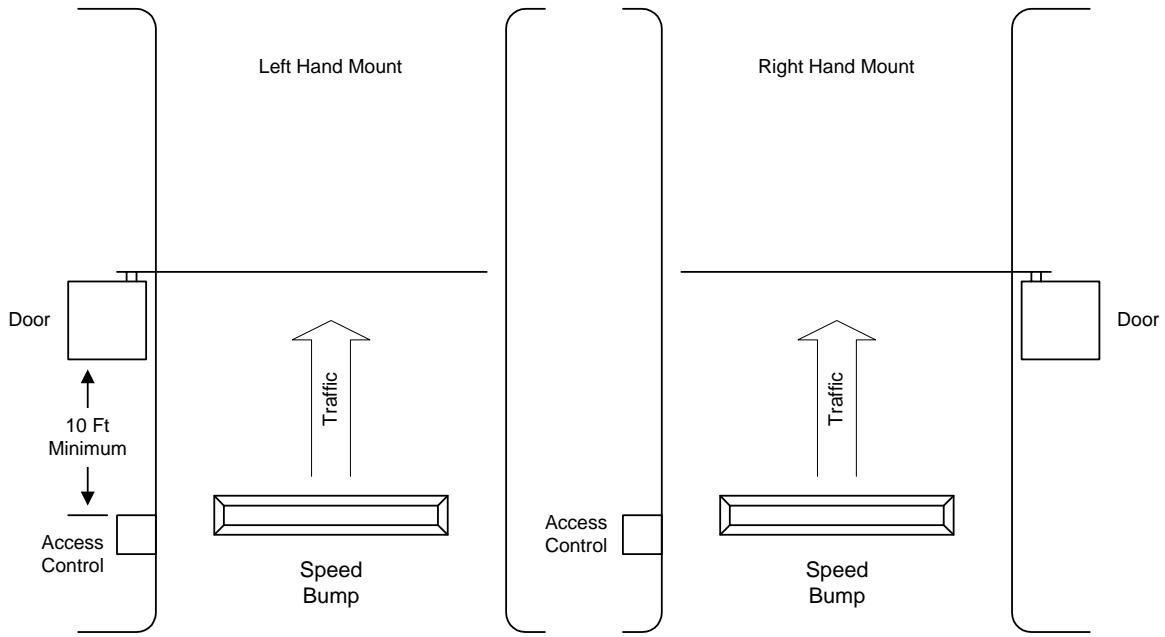

Figure 2

1.3 PAD CONSTRUCTION

The 1601 and 1602 operators are designed to be mounted directly to a concrete pad. The size of the pad specified below will allow four inches of clearance around the operator. This will prevent the pad from splitting or cracking when anchoring the operator to the pad.

1. Construct a form for the mounting pad according to the figures shown in the diagram below. Be sure to level the top edge of the form. The depth of the pad is determined by local soil conditions and local building codes, but should be at least 24 inches deep. We suggest that you contact the local building department to determine the proper depth of the pad.
2. Construct the form so that the top level of the pad is at least four inches above ground level. This will help prevent water from accumulating in the bottom of the operator.
3. Set conduits to center of pad (see below) and reinforcing bars and/or wire mesh if desired. The number of conduits is determined by the application requirements. Four conduits are shown below - one for high voltage power, one for low voltage control requirements, one for loop lead-in wiring, and one for sequencing control wiring or master/slave application.
4. Mix concrete according to the manufacturers instructions. Pour the mixture into the form and tamp. Level and finish the surface after pouring is complete. Do not set anchor bolts in the concrete. Sleeve anchors can be used to anchor the operator to the concrete after it has hardened and will allow you to position the operator on the pad exactly where you want it.
5. Allow the pad to cure for 48 hours before removing the forms or mounting the operator.

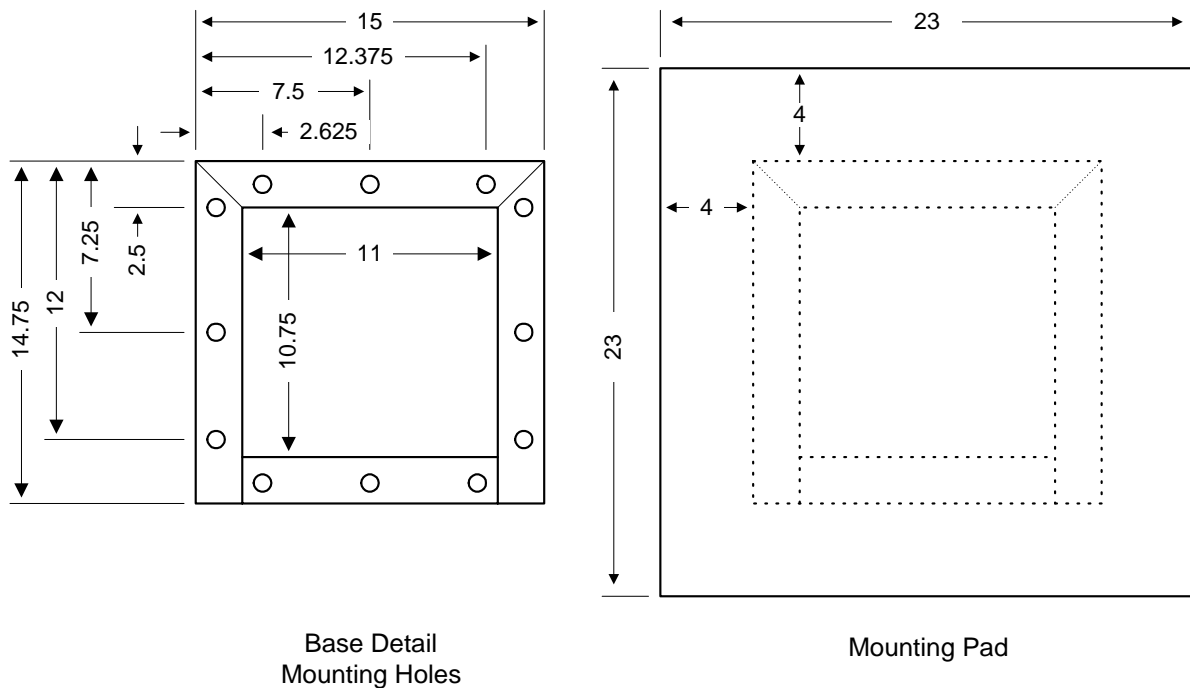

Figure 3

1.4 OPERATOR MOUNTING

Remove the operator from its shipping carton. Be sure to check the packing list against the shipment to be sure all necessary components are on hand.

1. Position the operator so that it is centered on the mounting pad and the door is facing away from the traffic lane.
2. Open the door of the operator and mark the mounting holes on the pad. Remove the operator from the pad.
3. Use a concrete drill bit and drill the mounting holes to the size and depth required for the anchors being used. Be sure to clean out the hole after you drill it. We recommend 3/8 x 3 or 1/2 x 3 inch sleeve anchors. Anchors are not supplied with the operator.
4. Reposition the operator on the mounting pad. Install the sleeve anchors in the mounting holes and tighten.

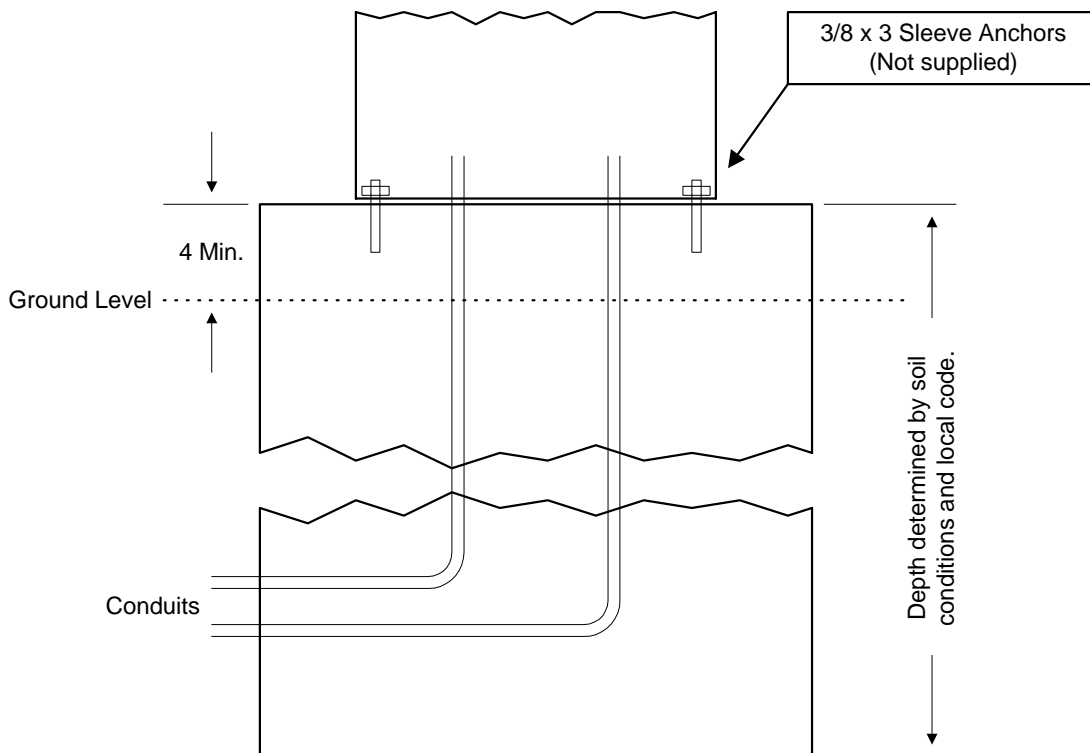

Figure 4

1.5 ARM MOUNTING HARDWARE INSTALLATION

The 1601 barrier gate operator is designed so that the arm can be mounted on either side of the cabinet. The 1602 arm is attached on both sides of the operator.

1. Determine which side of the cabinet that the arm is to be mounted. Remove the hole plug from the side of the cabinet to expose the drive shaft. Be sure that the hole plug is in place on the opposite side of the cabinet. 1602 - Remove the hole plug from both sides of the operator.
2. Place the arm-mounting hub on the drive shaft. Be sure that the hub is oriented in such a way that the mounting holes for the arm plate form an "X". 1602 - Repeat this step to place the hub on the opposite side.
3. Secure the mounting hub to the shaft as shown with the hardware supplied. 1602 - Repeat this step for the hub on each side of the operator.
4. **DO NOT MOUNT THE ARM TO THE OPERATOR AT THIS TIME!** The arm will be installed after wiring is complete so that the rotation direction of the shaft can be checked to insure that the arm will rotate to the up position when the operator receives an open command. Installing the arm prior to this can cause damage to the arm and to the operator. See section 4.1 for arm installation instructions.

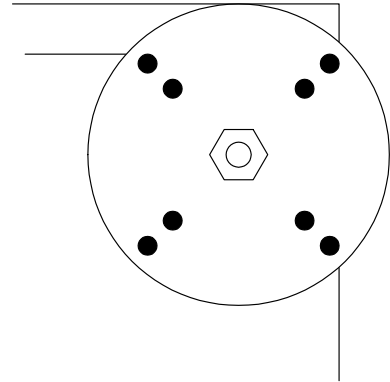

Figure 5

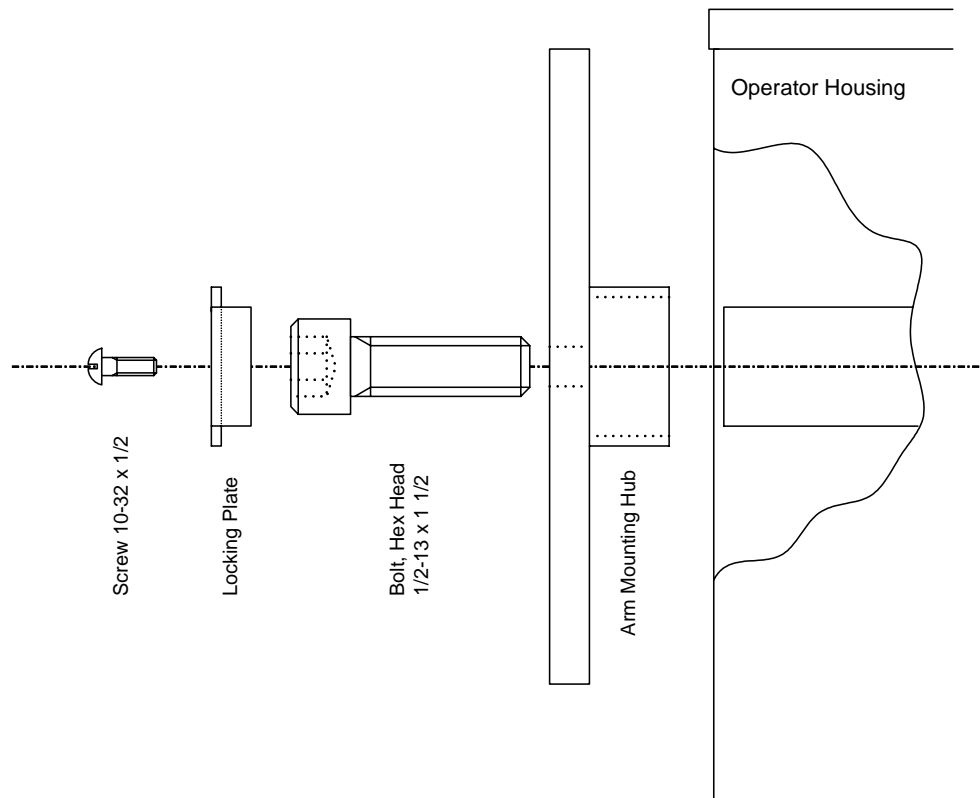

Figure 6

SECTION 2 – ELECTRICAL

Before attempting to connect any wiring to the operator, be sure that the circuit breaker in the electrical panel is in the OFF position. Permanent wiring must be installed to the operator as required by local electrical codes. It is recommended that a licensed electrical contractor perform such work.

Since building codes vary from city to city, we highly recommend that you check with your local building department prior to installing any permanent wiring to be sure that all wiring to the operator (both high and low voltage) complies with local code requirements.

THIS GATE OPERATOR MUST BE PROPERLY GROUNDED!

2.1 CONDUITS

The conduit requirements shown are typical for a barrier gate operator installation. The conduit requirements for your application may vary from this depending on your specific needs. Use only sweeps for conduit bends. Do not use 90° connectors as this will make wire pulls very difficult and can cause damage to wire insulation. We suggest that minimum 3/4-inch conduit be used. Be sure that all conduits are installed in accordance with local codes.

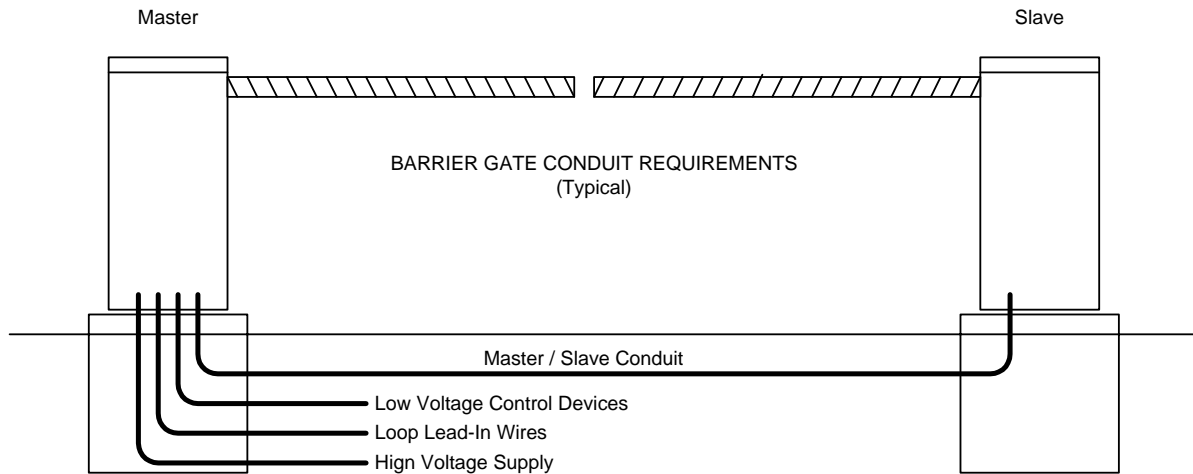

Figure 7

2.2 HIGH VOLTAGE WIRING

Use Table 1 to determine high voltage wire size requirements. The distance shown in the chart is measured in feet from the operator to the power source. If power wiring is greater than the maximum distance shown, it is recommended that a service feeder be installed. When large gauge wire is used, a separate junction box must be installed for the operator connection. The wire table is based on stranded copper wire. Wire run calculations are based on a 3% voltage drop on the power line, plus an additional 10% reduction in distance to allow for other losses in the system.

MODEL	VOLTS	AMPS	WIRE SIZE / DISTANCE IN FEET			
			12 AWG	10 AWG	8 AWG	6 AWG
1601	120	5.4	170	275	460	685
1601	230	2.7	685	1100	1830	2750
1601	460	1.35	2875	4600	7665	11500
1602	120	14.0	130	210	350	530
1602	230	7.0	530	845	1415	2120
1602	460	3.5	1110	1775	2955	4435

Table 1

- Route incoming high voltage power through conduit and into the operator as shown.
- Be sure wiring is installed in accordance with local codes. Be sure to color code all wiring.
- Connect incoming power to terminal block as shown.
- It is recommended that a surge suppresser be installed on the high voltage power lines to help protect the operator and circuit board from surges and power fluctuations.
- **NOTE 1:** For 230 and 460 Volt 3-phase input power, use only two legs of the incoming 3-phase power.

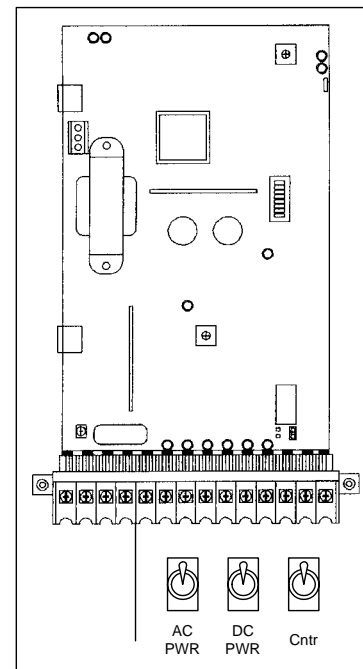
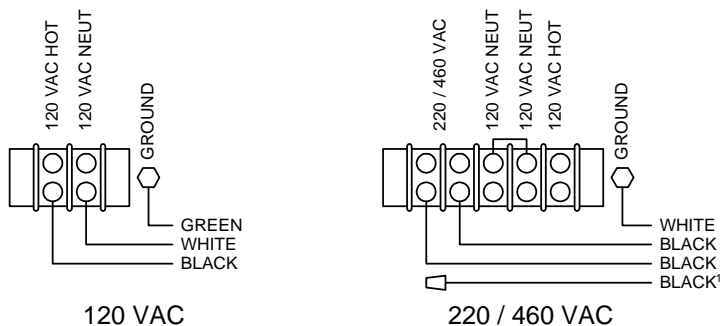

Figure 8

2.3 LOW VOLTAGE WIRING

Controls must be far enough from the barrier operator so that the user is prevented from coming in contact with the operator or arm while operating the controls. Outdoor or easily accessible controls should have a security feature to prevent unauthorized use.

2.3.1 CONTROL WIRING

- Connect optional control devices to the operator terminal strip as shown. Be sure that all electrical connections are made in accordance with local electrical codes. Use 18 AWG wire for all low voltage wiring, maximum distance 3000 feet. Use a low voltage surge suppresser, DoorKing P/N 1878-010 if low voltage wire runs exceed 1000 feet. All inputs to the terminal strip must be NORMALLY OPEN.
- Do not power any devices from the circuit board other than a low voltage radio receiver as shown. Additional accessory items such as card readers or keypads must be powered from their own power transformer.
- If this operator is part of a Perimeter Access Management System (PAMS), refer to your PAMS wiring manual and section 2.3.3 for interface wiring to the swing or slide gate operator.

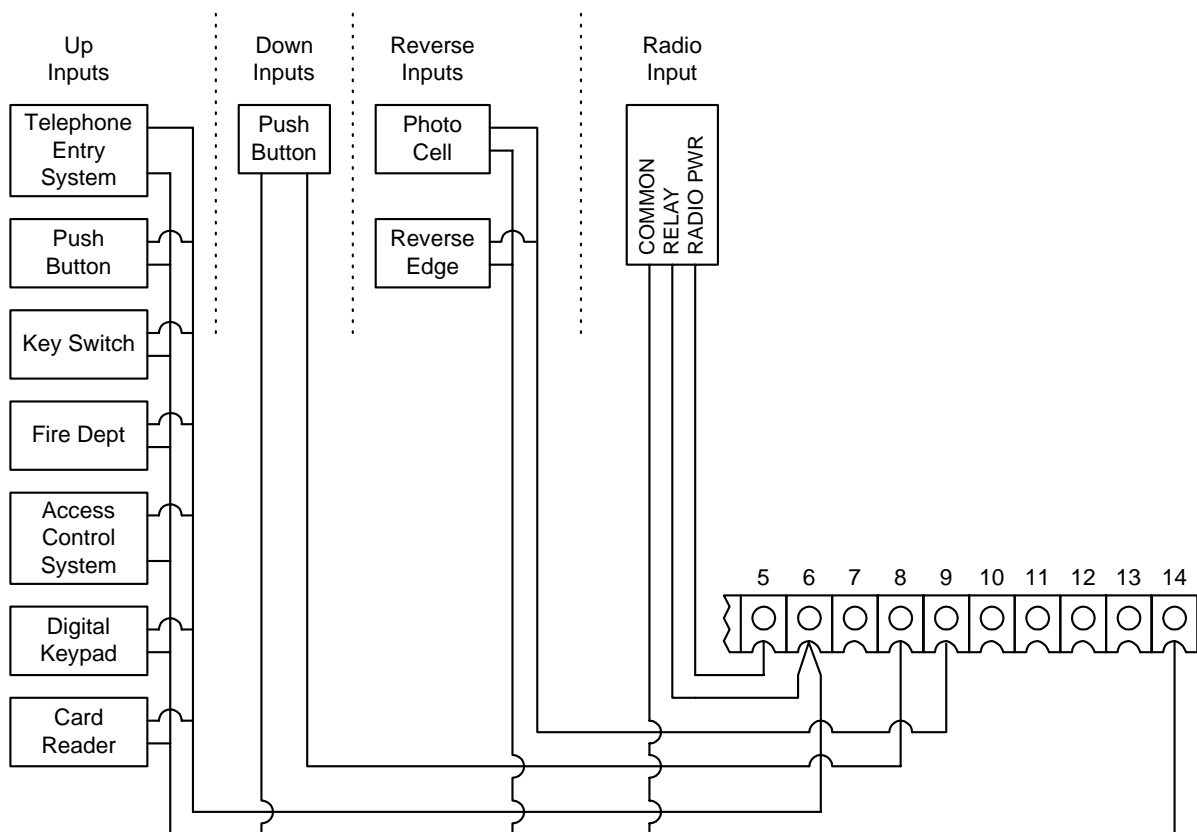

Figure 9

2.3.2 MASTER / SLAVE CONTROL WIRING

Two 1601 or 1602 operators may be wired together so that the units operate in unison as a master / slave set. Each operator must be connected to its own high voltage source as described on page 8.

1. Connect terminal 6 to terminal 6.
Connect terminal 8 to terminal 8.
Connect terminal 9 to terminal 9.
Connect terminal 14 to terminal 14.
2. If an open loop is used, plug the loop detector into the **UP** loop port of either unit.
Set programming switch 5 to ON.
Jumper terminal 12 to terminal 6.
Jumper terminal 13 to terminal 14.
3. If a down loop is used, plug the loop detector into the **DOWN** loop port of the **opposite** unit.
Set programming switch 5 to OFF.
Jumper terminal 12 to terminal 8.
Jumper terminal 13 to terminal 14.
4. Connect control devices to the master unit as described in section 2.3.1.

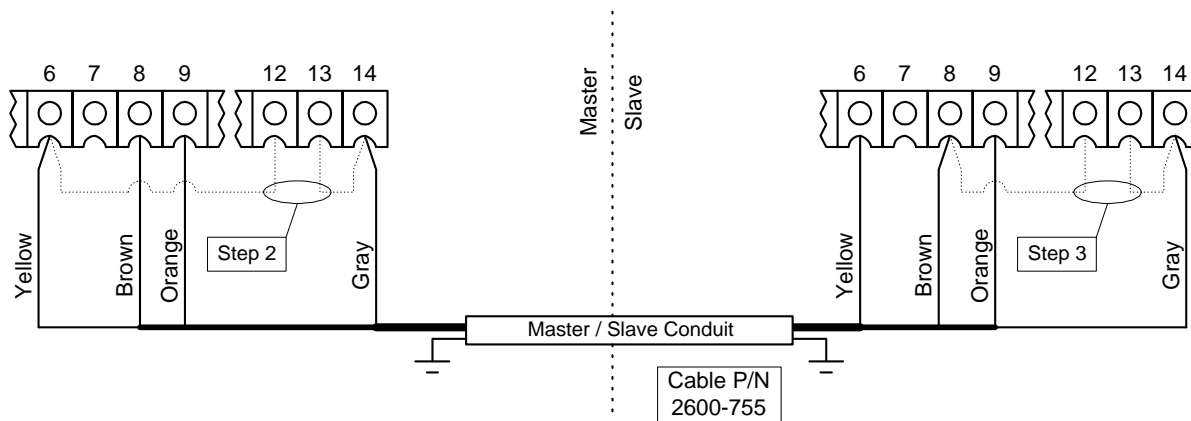

Figure 10

2.3.3 PAMS CONTROL WIRING

If this operator is used in a Perimeter Access Management System (PAMS) application, refer to the diagrams below for PAMS wiring interface to sequence the barrier operator with the slide or swing gate operator. For detailed PAMS wiring information, refer to the PAMS Technical Information and Wiring Manual.

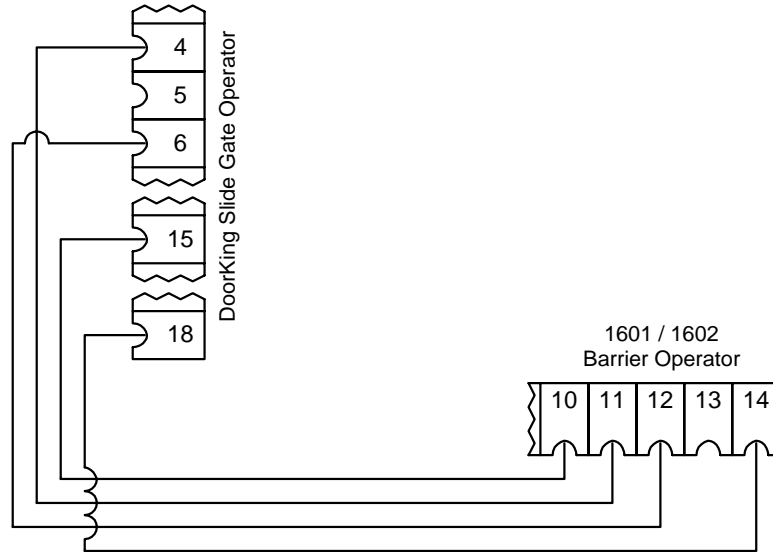

Figure 12

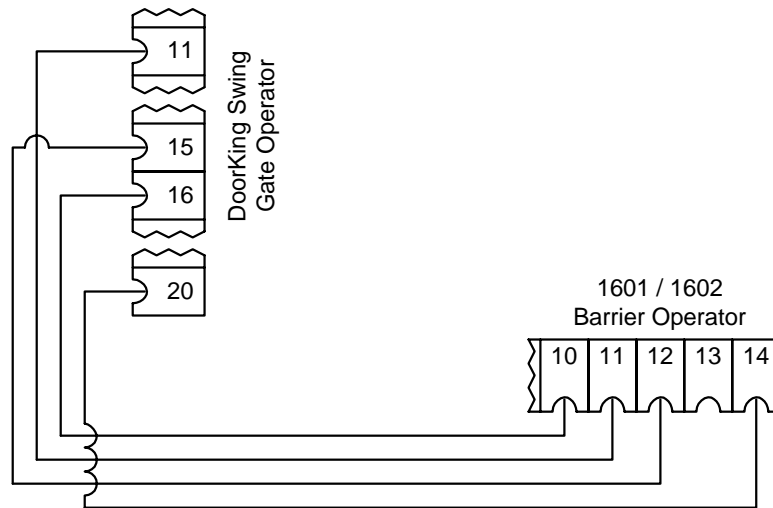

Figure 11

2.3.4 GATE TRACKER™ WIRING

This barrier operator is equipped with outputs from the circuit board that will report operator status to a companion DoorKing Access Control System (Model 1803PC, 1815, 1817 or 1818) that is equipped with a Tracker expansion board. This report includes items such as operator cycle count, any shorted inputs, loop detector problems, power interruptions, etc.

The Gate Tracker™ connections are made at the auxiliary terminal strip located on the left side of the circuit board, and at terminals 5, 6 and 14 on the main terminal strip. For more detailed information on Gate Tracker™ and wiring to the Tracker expansion boards, refer to the Tracker Installation and Wiring Manual, DoorKing P/N 2351-010.

- Maximum wire run for gate operator data to the tracker board is 500 feet using Belden #9931 shielded cable or Consolidated #5324-CL shielded cable. **Float the shield at the tracker board. Do not connect the shield to the tracker board common.**
- Wire connection from the tracker board terminal P1-6 to the 1601 / 1602 main terminal 6 is optional **if the barrier operator is not to be activated by the tracker output relay.**

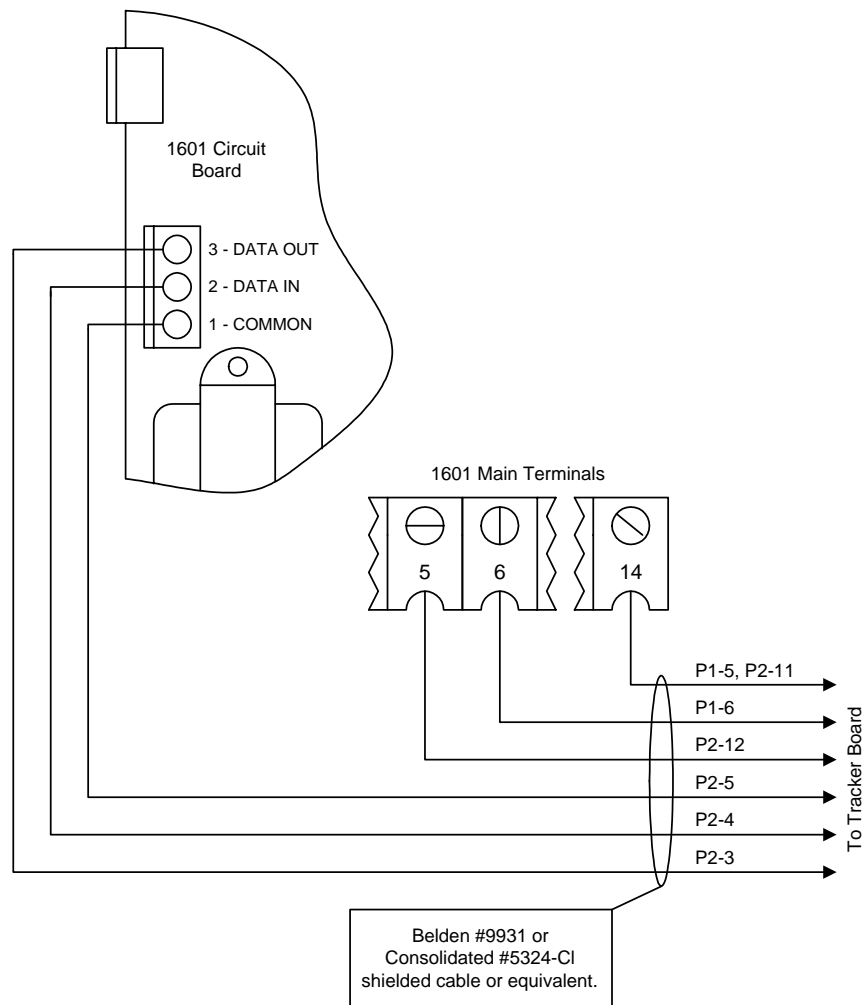

Figure 13

2.4 LOOP DETECTOR WIRING

Loop detector wiring is shown for DoorKing model 9405 and 9406 Plug-In loop detectors only. If other loop detectors are used, refer to the wiring diagrams that are included with the detectors.

- Be sure that power is turned off prior to making any connections to the terminal strip.
- If other loop detectors are used, all inputs to the terminal strip are NORMALLY OPEN.
- Loop layouts shown are for typical barrier gate applications.
- Refer to the separate Loop Information Manual (available from DoorKing) for instructions on installing loops or preformed loops.

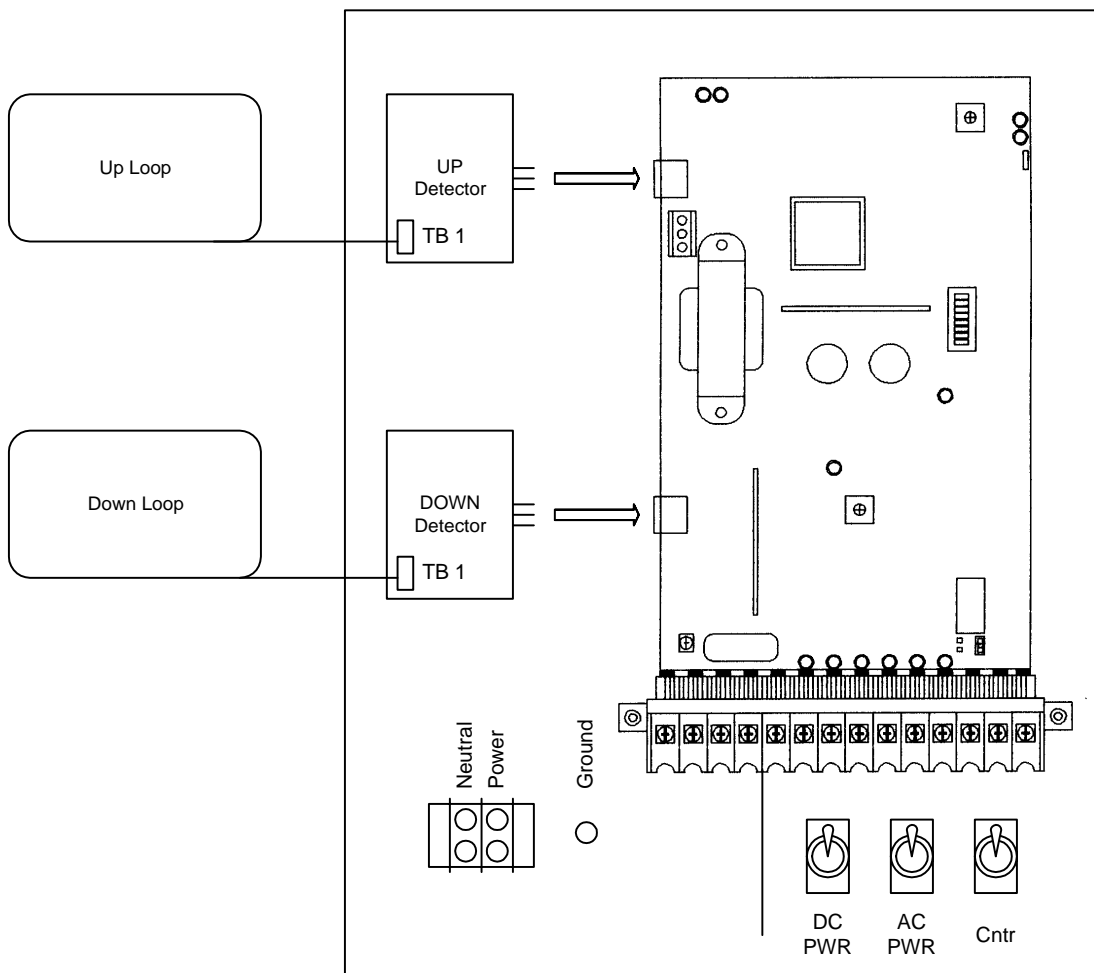

Figure 14

2.4.1 ENTRY LANE APPLICATION

- Use a 9405 loop detector plugged into the DOWN port on the 1601 circuit board. Connect the DOWN loop to terminals TB-1 and the ARMING loop to terminals TB-2.
- If the optional arming loop is not used, use a 9406 detector plugged into the DOWN port on the 1601 circuit board and connect the DOWN loop to terminals TB-1 on this detector.
- The timer (SW-1, switch 7) should be OFF. The arm will rotate down after the vehicle clears the down loop.
- SW-1, switch 4 must be ON.

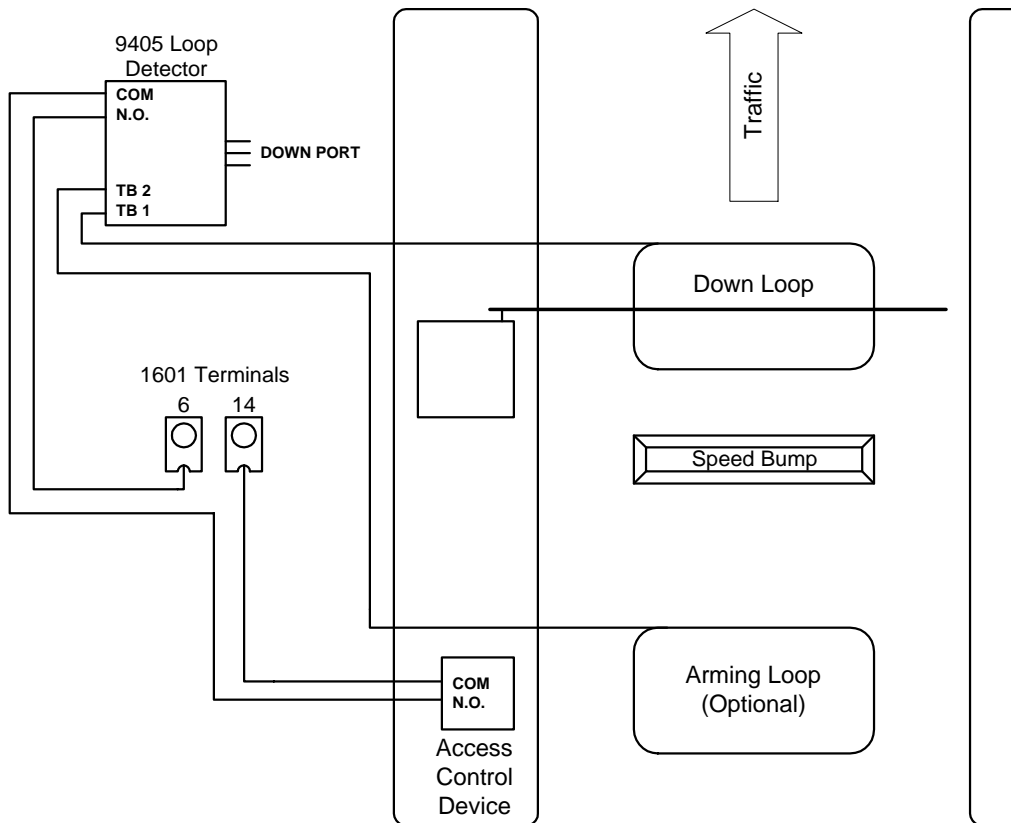

Figure 15

2.4.2 EXIT LANE APPLICATION

- Use a 9406 detector plugged into the DOWN port on the 1601 circuit board and connect the DOWN loop to terminals TB-1 on this detector.
- Use a second 9406 detector plugged into the UP port on the 1601 circuit board and connect the EXIT loop to terminals TB-1 on the detector.
- The timer (SW-1, switch 7) should be OFF. The arm will rotate down after the vehicle clears the down loop.
- SW-1, switch 4 must be ON.

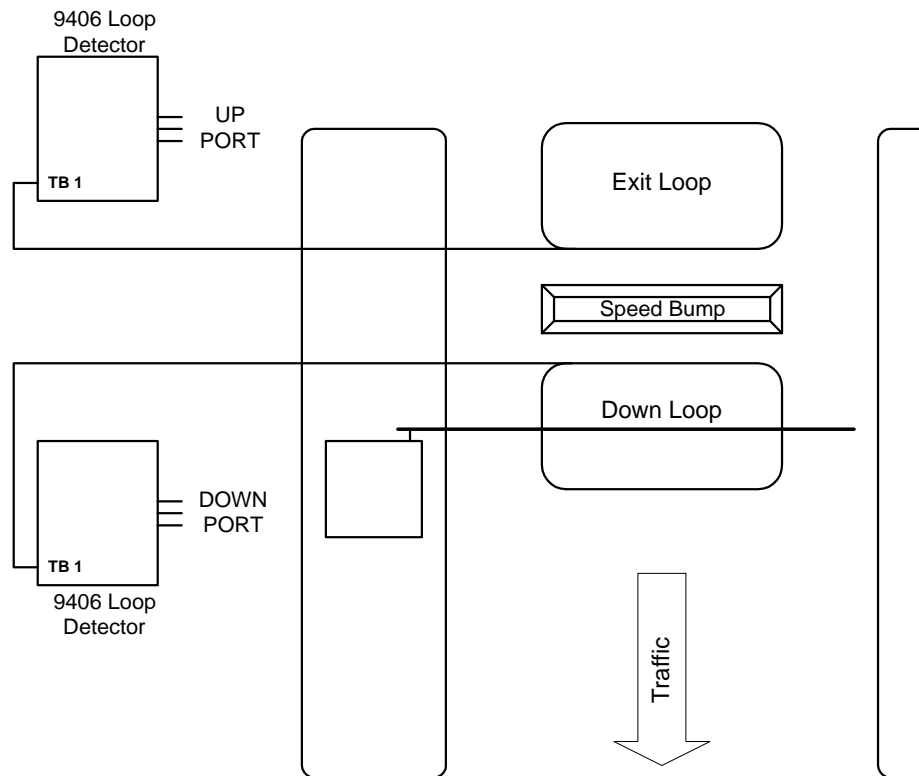

Figure 16

2.4.3 TICKET SPITTER APPLICATION

- Use a 9405 loop detector plugged into the DOWN port on the 1601 circuit board. Connect the DOWN loop to terminals TB-1 and the TICKET EJECT loop to terminals TB-2.
- The timer (SW-1, switch 7) should be OFF. The arm will rotate down after the vehicle clears the down loop.
- SW-1, switch 4 must be ON.

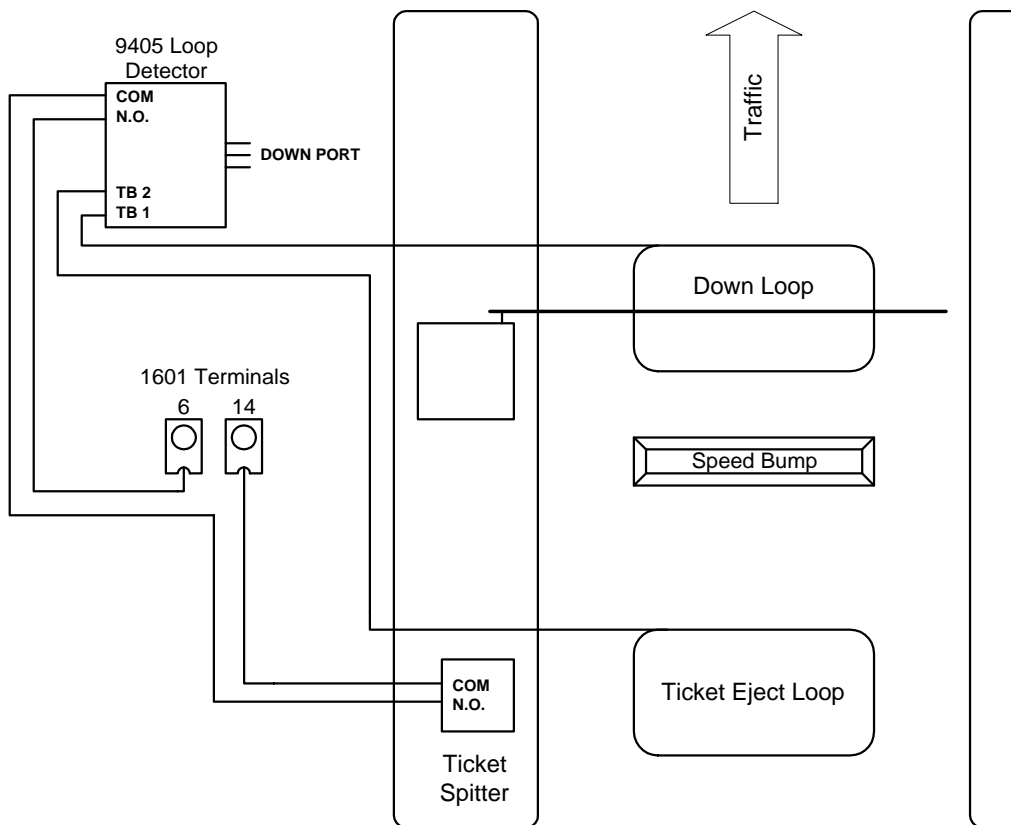

Figure 17

2.4.4 TWO-WAY LANE APPLICATION

- Plug a 9406 loop detector into the UP loop port on the 1601 circuit board and connect the EXIT loop to terminals TB-1.
- Use a 9405 loop detector plugged into the DOWN port on the 1601 circuit board. Connect the DOWN loops, wired in series, to terminals TB-1 and the ARMING loop to terminals TB-2.
- If the optional arming loop is not used, use a 9406 detector plugged into the DOWN port on the 1601 circuit board and connect the DOWN loops, wired in series, to terminals TB-1 on this detector.
- The timer (SW-1, switch 7) should be OFF. The arm will rotate down after the vehicle clears the down loops.
- SW-1, switch 4 must be ON.
- Spacing of the loops is critical when using this configuration. Be sure that the loops are spaced as shown in the diagram.

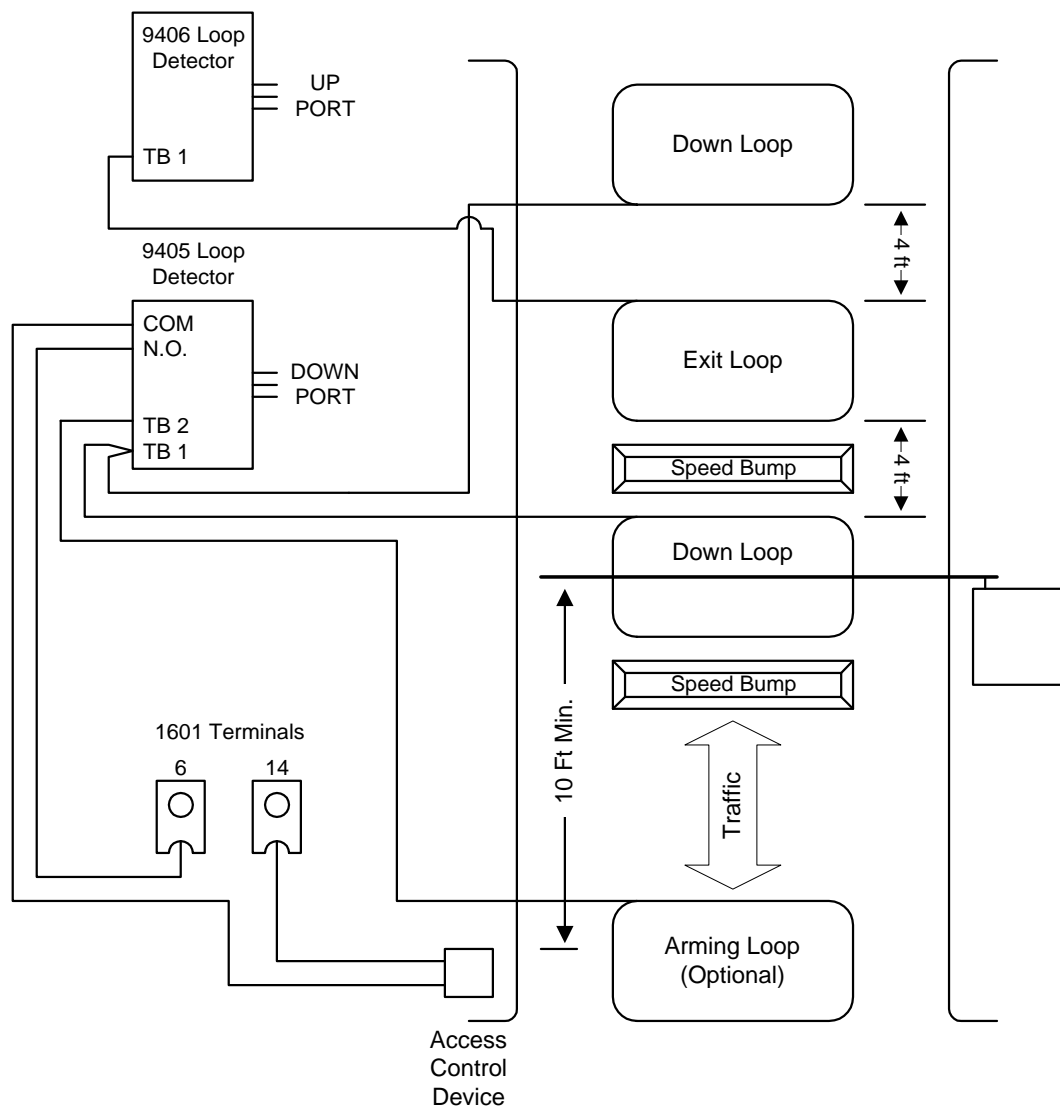

Figure 18

2.4.5 TIMER DOWN APPLICATION

- Use a 9405 loop detector plugged into the DOWN port on the 1601 circuit board. Connect the REVERSE loops, wired in series, to terminals TB-1 and the ARMING loop to terminals TB-2.
- If the optional arming loop is not used, use a 9406 detector plugged into the DOWN port on the 1601 circuit board and connect the REVERSE loops, wired in series, to terminals TB-1 on this detector.
- The timer (SW-1, switch 7) should be ON. The arm will rotate down after the vehicle clears the reverse loops and the timer times out.
- SW-1, switch 4 must be OFF.
- Spacing of the loops is critical when using this configuration. Be sure that the loops are spaced as shown in the diagram.

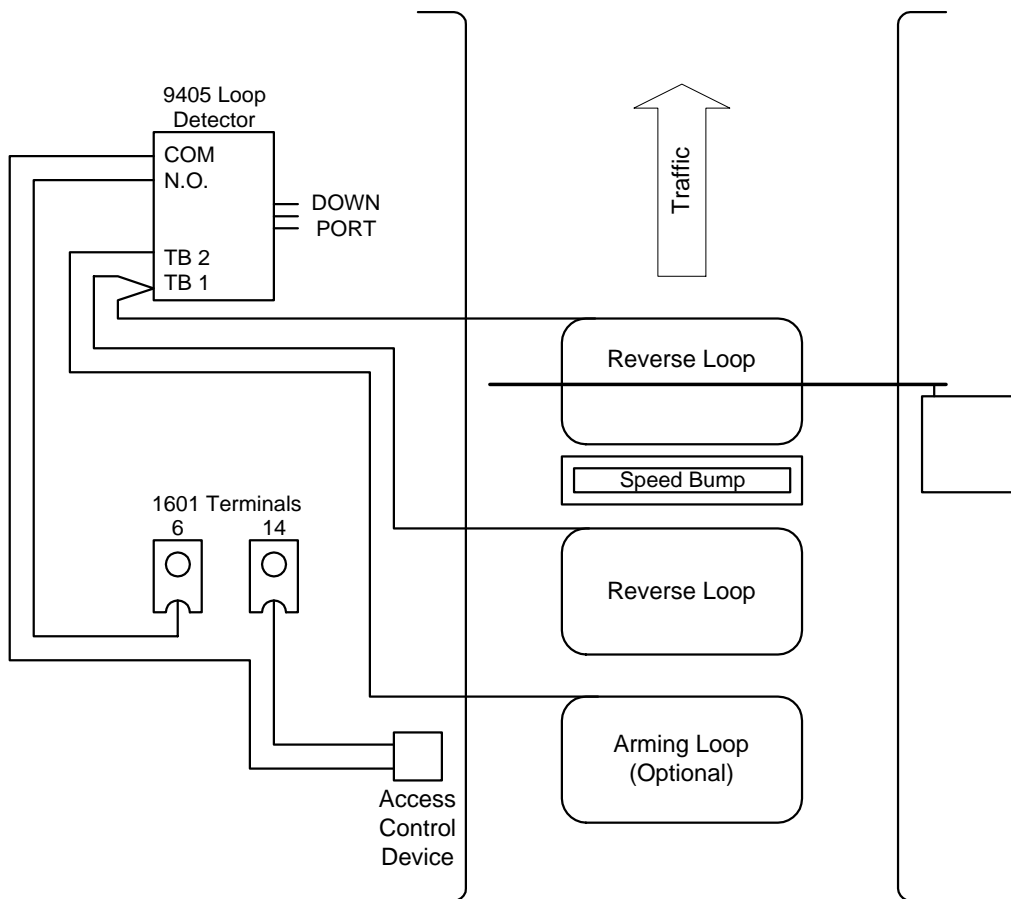

Figure 19

2.5 MAIN TERMINAL IDENTIFICATION AND DESCRIPTION

- 1 **115 VAC Neutral**
- 2 **115 VAC Power**
- 3 **115 VAC Motor Power**
- 4 **115 VAC Motor Power**
- 5 **24 VAC Radio Receiver Power Only (200 ma. maximum)**
- 6 **UP input.** Function is dependent on the setting of programming switch 6. When switch 6 is OFF, this input will cause the operator to rotate the arm to the up position. If the arm is in the down cycle, this input will reverse the arm to the up position. If this terminal has a constant input, the arm will remain in the up position regardless of any down input or timer command to rotate down. When switch 6 is ON, this input will cause the operator to rotate the arm to the up position when it is down, and will cause the operator to rotate the arm to the down position when it is up. If the auto timer is turned ON, this input will override the timer and rotate the arm to the down position. If the arm is in the down cycle, this input will reverse the arm to the up position.
- 7 **UP / UP LOOP OUTPUT.** Function is dependent on the setting of programming switch 8. When switch 8 is ON, the function of this input is identical to terminal 6 above. When switch 8 is OFF, this terminal becomes the logic output of the up loop detector.
- 8 **DOWN / REVERSE INPUT.** Function is dependent on the setting of programming switches 1 and 4. With switch 1 OFF and switch 4 ON, activation and then deactivation of this input will rotate the arm to the down position, provided that the deactivation of the input happens while the arm is in the full up position. This input will override the auto timer if it is turned ON. If the arm is in the down position, traveling in the down cycle, or traveling in the up cycle, activation and deactivation of this input has no effect on the arm. With switches 1 and 4 ON, activation and then deactivation of this input will rotate the arm to the down position after it reaches the full up position regardless of when the deactivation of the input occurred. When switch 4 is OFF, this input is identical to the reverse input, terminal 9.
- 9 **REVERSE input.** When the arm is in the down position, activation of this input has no effect. When the arm is in the up position, activation of this input will prevent the arm from rotating to the down position. If the arm is in the down cycle, activation of this input will reverse the arm to the up position.
- 10 **MOMENTARY UP input.** This input is used when sequencing the 1601 with a slide or swing gate operator in PAMS applications. Activation of this input will rotate the arm to the up position one time, and activates the enable up input.
- 11 **ENABLE UP input.** This input is used when sequencing the 1601 with a slide or swing gate operator in PAMS applications. This input is only active after a MOMENTARY UP input is received. Activation of this input will rotate the arm to the up position or reverse an arm in the down cycle to the up position.
- 12 **RELAY CONTACT.** Function is dependent on the setting of programming switch 5. When switch 5 is OFF, activation of the down loop will activate the relay. When switch 5 is ON, activation of the UP loop will activate the relay. Relay contacts can be set for N.O. or N.C. by placing the relay contact jumper on the appropriate pins.
- 13 **RELAY CONTACT.** Same as above.
- 14 **LOW VOLTAGE COMMON.**

SECTION 3 – ADJUSTMENTS

The switch settings and adjustments in this chapter should be made after your installation and wiring to the operator(s) is complete. Whenever any of the programming switches on the circuit board are changed, power must be shut-off, and then turned back on for the new setting to take effect.

3.1 CIRCUIT BOARD ADJUSTMENTS

- Set the DIP-switches on the circuit board to the desired setting. See switch-setting charts in section 3.2.
- Auto close timer (when turned on) can be set from 1 second (full counter clockwise) to approximately 60 seconds (full clockwise).
- Rotate the REVERSE SENSITIVITY potentiometer clockwise to increase sensitivity, counter clockwise to decrease sensitivity.
- Relay 1 contacts (terminals 12-13) can be set for Normally Open (NO) or Normally Closed (NC) operation by placing the relay shorting bar on the NO or NC pins respectively. **Relay activation is dependant on setting of SW1, switch 5.**
- Arm Relay contacts (C – NC – NO) are available on the small terminal strip. **This relay activates only when gate arm is in the FULL UP position.**
- Power LED indicates that low voltage power is applied to the circuit board. The input LEDs should be OFF and will only illuminate when the input is activated.
- Limit LEDs will be ON when the arm is in the respective position.
- Tracker Activity LEDs indicate data communication to the optional Tracker board.

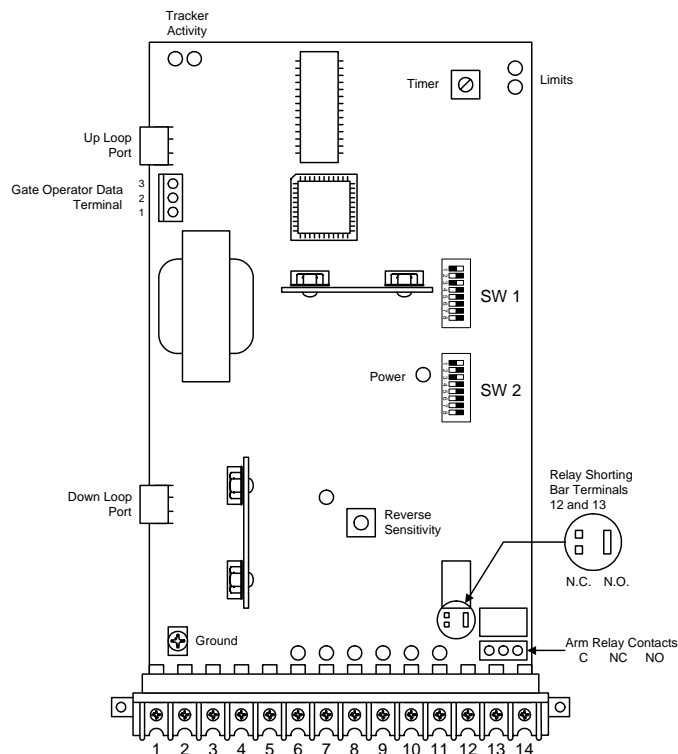

Figure 20

3.2 SWITCH SETTINGS

The two DIP-switches located on the circuit board are used to set operating modes and to turn on or off various operating features. The TOP switch set is referred to as SW1, while the BOTTOM switch set is referred to as SW2. Whenever a switch setting is changed, power to the operator must be turned OFF, and then turned back on for the new setting to take affect. **Check and review ALL switch settings prior to applying power to the operator.**

SW 1 (TOP SWITCH)			
SWITCH	FUNCTION	SETTING	DESCRIPTION
1	Down Active when arm is full up	OFF	Activation and then deactivation of the down loop or down / reverse input will cause the arm to rotate down ONLY if the deactivation occurred after the arm reached the FULL UP position.
	Down Active when arm is moving up or is up	ON	Activation and then deactivation of the down loop or down / reverse input will cause the arm to rotate down AFTER reaching the FULL UP position regardless of when the deactivation occurred.
2	Self Test	OFF	Normal setting. Self-test is turned off.
		ON	Runs self test.
3	Gear Box Travel	OFF	Normal setting. Operator uses 360° of gearbox.
		ON	Alternate setting. Operator uses 180° of gearbox.
4	Down / Reverse Loop and Input	OFF	Down / Reverse loop and input will function as a REVERSE loop and REVERSE input.
		ON	Normal setting. Down / Reverse loop and input will function as a down input and cause the arm to rotate down upon deactivation of the input. See SW 1, switch 1 for additional information.
5	Relay 1 Activation	OFF	Normal setting. Relay activates when the DOWN loop detector (DoorKing plug-in detector only) senses a vehicle presence.
		ON	Relay activates when the UP loop detector (DoorKing plug-in detector only) senses a vehicle presence.
6	Up Input Function	OFF	Up Input will raise arm and/or reset the down timer. Input will not lower the arm.
		ON	Up Input will raise arm if it is down, or will lower arm if it is up.
7	Time Delay	OFF	Time delay to lower arm is OFF.
		ON	Time delay to lower arm is ON.
8	UP Loop Port Output	OFF	Output of the loop detector plugged into the UP loop port is switched to terminal 7 for connection to other input terminals.
		ON	Normal setting. Output of the loop detector plugged into the UP loop port will raise arm when activated.

SW 2 (BOTTOM SWITCH)			
SWITCH	FUNCTION	SETTING	DESCRIPTION
1	Operator Model	OFF ON	Switch must be set OFF for model 1601 operators. Switch must be set ON for model 1602 operators. This setting adds a 2-second delay on reverse and closing commands and overrides SW2, switch 5 settings.
2	Multiple Input Memory	OFF ON	Normal Operation. Operator will respond to most recent command. If multiple UP inputs are received, the NEXT down command will lower arm. Remember multiple inputs. SW 1, switch 4 must also be on.
3	Multiple Input Memory Options	OFF ON	Second Car Down – If a vehicle is on the down loop when the 1601 receives another UP command, the operator will ignore the close command when the first vehicle clears the down loop and will require the second vehicle to clear the down loop to lower the arm. Multiple Up Commands – The 1601 will count the number of UP commands it receives and will require a matching number of down commands to lower the arm whether or not down loop is active.
4	Stop Loop Function	OFF ON	Normal Operation. The down loop is inactive DURING the down cycle. Stop Loop – If a vehicle activates the down loop during the down cycle, the arm will STOP. An UP command will raise the arm, or the arm will continue down AFTER the loop is cleared.
5	1601 Reversing	OFF ON	Normal Operation. Arm reversal is delayed approximately .5 second when a reverse command is received during the down cycle. Instant Reverse – Arm reversal is delayed approximately .1 second when a reverse input (terminal 9) is received during the down cycle.
6	Direction	OFF ON	Changes direction of arm rotation.
7	Spare	OFF	No Function. Leave in OFF position.
8	Spare	OFF	No Function. Leave in OFF position.

3.3 MAGNETIC LIMIT ADJUSTMENT

This barrier gate operator uses magnetic limits that are preset at the factory to rotate the arm 90°. No adjustment of the limit magnets are necessary when the operator is used in a normal configuration. If it becomes necessary for the arm to rotate less than 90°, follow the steps below to adjust the magnetic limits.

1. Adjust the magnetic limits only if it is necessary for the arm to rotate less than 90°. Remove the barrier arm(s) from the operator prior to making any magnetic limit adjustments.
2. Be sure that DIP-switch 3 is in the **ON** position. This changes the rotation of the gearbox from 360° to 180°, and allows the magnetic limits to stop the rotation at less than 180° if necessary. This will cause the arm to rotate less than 90°.
3. Be sure that all power to the barrier operator is turned **OFF** at the breaker panel.
4. Loosen the adjusting nuts on the back of the limit magnets so that they can slide in the mounting slot.
5. Moving the magnets towards each other shortens the rotation of the output shaft. The maximum rotation of the output shaft is 90°.
6. Tighten the adjusting nuts prior to reapplying power to the operator.
7. Check the shaft rotation by activating the UP input. To prevent possible damage to the operator and the barrier arms, be sure that the barrier arm(s) **are not** installed on the operator during these initial checks.
8. Repeat steps 3 through 6 until the desired rotation is achieved.

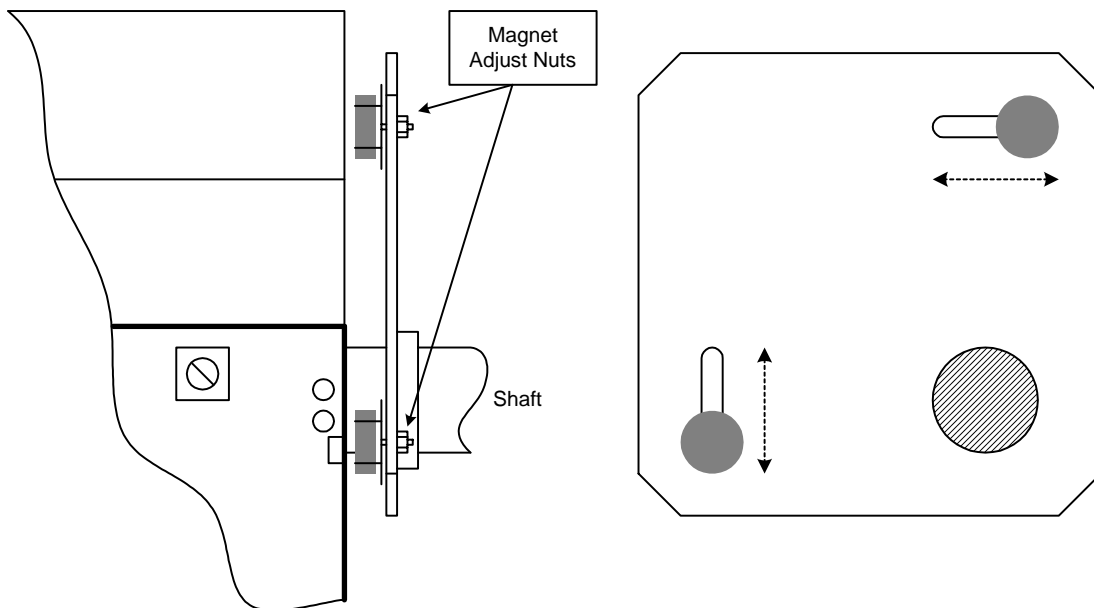

Figure 21

3.4 REVERSE SENSITIVITY ADJUSTMENT

The barrier gate operator is equipped with an Electronic Reversing Device (ERD) which will cause the barrier arm to reverse direction of travel should an object be encountered during the down cycle. The amount of force required for the arm to reverse direction is dependent on the setting of the reverse sensitivity potentiometer. The ERD has no effect on the arm travel should an object be encountered by the arm in the up direction. Follow the instructions below to adjust the ERD potentiometer.

The ERD will have to be adjusted after the arm has been installed on the barrier operator. Do not adjust the ERD until after the arm has been installed per section 4.1.

1. Turn the AC power toggle switch to the ON position.
2. Place the control toggle switch to the UP position. The arm should rotate UP.
3. Momentarily press the control toggle switch to the DOWN position. This will cause the arm to rotate down. **CAUTION:** Be sure that all persons and vehicles are clear of the arm before pressing the down toggle switch!
4. While the arm is traveling in the down direction, rotate the reverse potentiometer clockwise until the reverse LED illuminates. The arm will reverse travel at this time.
5. Rotate the reverse potentiometer 1/8 turn counter clockwise.
6. You may have to repeat the adjustment a few times to find a satisfactory setting.

The ERD in the barrier operator is not intended to replace external reversing devices such as loops, photo electric eyes, or reversing edges. It is important that these devices be installed according to the needs and requirements of your particular application.

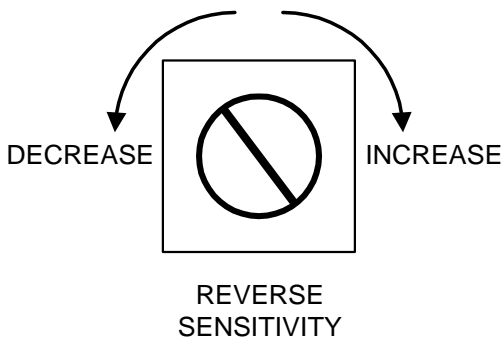

Figure 22

3.5 OPERATING TESTING

Be sure that power to the barrier operator is OFF before changing any programming switches, or wiring any control devices to the operator. **Be sure that the barrier arm(s) ARE NOT INSTALLED AT THIS TIME!**

1. Set the programming selection switches on the circuit board for the desired operation. Anytime the programming switches are changed, power to the operator must be turned OFF, and then turned back ON for the changes to take affect.
2. Be sure that the AC POWER and DC POWER toggle switches are in the OFF position, and that the control toggle switch is in the center (neutral) position.
3. Turn the AC power switch to the ON position. The operator should not start. The power LED on the control board should be illuminated. Either the UP LED or the DOWN LED may be illuminated depending on the position of the output shaft. If neither LED is illuminated, this indicates that the shaft is between the magnetic limits.
4. If the UP LED is illuminated, push the control toggle switch to the DOWN position. The shaft should rotate until the DOWN LED illuminates.
If the DOWN LED is illuminated, or if neither LED is illuminated, push the control toggle switch to the UP position. The shaft should rotate until the UP LED illuminates.
5. Operate all keying devices (radio control, key switch, card reader, telephone entry system, digital lock, Fire Department lock box, open loop, etc.) to be sure that they activate the barrier arm operator.
6. Check the operation of the down loop (if used). When the UP LED is illuminated, activation of the DOWN loop should have no effect on the operator. When the down loop is deactivated (the vehicle leaves the loop area), the operator shaft should rotate to the down position. Activation of the down loop while the DOWN LED is illuminated should have no effect on the operator.
7. Check the operation of the reverse loop (if used). When the UP LED is illuminated, activation of the reverse loop should hold the timer and prevent the operator shaft from rotating down. Activation of the reverse loop while the operator is rotating the shaft to the down position should cause the shaft to reverse direction to the up position. Activation of the reverse loop while the DOWN LED is illuminated should have no effect on the operator.
8. Adjust the auto close timer for the desired time that the arm will remain up before automatically closing (1-23 seconds).

SECTION 4 – ARM AND ACCESSORY INSTALLATION

Prior to installing the arm(s) onto the shaft of the barrier operator, the direction of rotation of the output shaft must be checked. The direction of rotation to raise the arm to the up position is dependent on how the operator has been installed (door of the operator opposite the traffic lane, or door of the operator facing the traffic lane), and if the operator has been installed on the left or right hand side of the traffic lane. **It is important that the output shaft rotation be checked BEFORE installing the arm(s) onto the operator.** If the output shaft rotation is in the opposite direction for your particular application and the arm(s) has been installed prior to checking the rotation direction, damage to both the arm(s) and the operator may result when the operator is placed in service.

4.1 ARM INSTALLATION

4.1.1 DIRECTION CHECK

1. Turn power to the barrier operator ON and momentarily place the control toggle switch to the UP position. When the operator starts, note the direction of rotation of the output shaft. If the shaft rotates in the right direction, proceed to section 4.1.2, 4.1.3 or 4.1.4. If the shaft rotates in the wrong direction, continue with step 2 in this section.
2. Turn power to the operator OFF.
3. Remove the plastic cover from the 1601-010 circuit board.
4. Flip the magnet over. NOTE: Each magnet has a small indent on one side. If the indent is facing out, flip the magnet so that it is facing in, or if the indent is facing in, flip the magnet so that it is facing out.
5. Manually turn the drive pulley so that the other magnet rotates to a position where it is accessible.
6. Flip this magnet over. NOTE: Each magnet has a small indent on one side. If the indent is facing out, flip the magnet so that it is facing in, or if the indent is facing in, flip the magnet so that it is facing out. **IMPORTANT!! One magnet must have the indent facing out and one magnet must have the indent facing in.**
7. Replace the plastic circuit board cover and repeat step 1 to check shaft rotation.

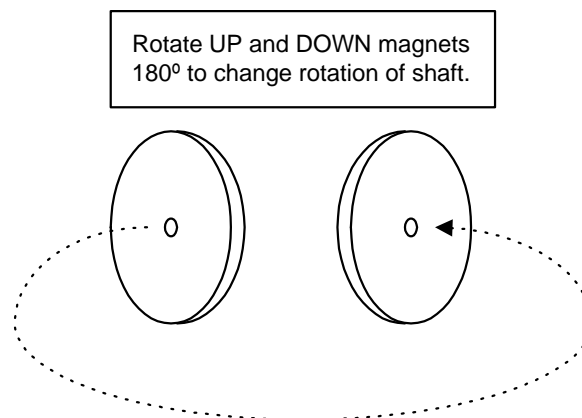

Figure 23

4.1.2 ARM MOUNTING HUB INSTALLATION

Follow these instructions to install the arm mounting hub onto the 1601 and 1602 operators. The 1602 operator requires a mounting hub on each side of the operator housing to accommodate the wishbone style arm.

1. Be sure that the shaft rotation has been checked as described in 4.1.1.
2. Install the arm hub using the supplied hardware as shown in the illustration below.

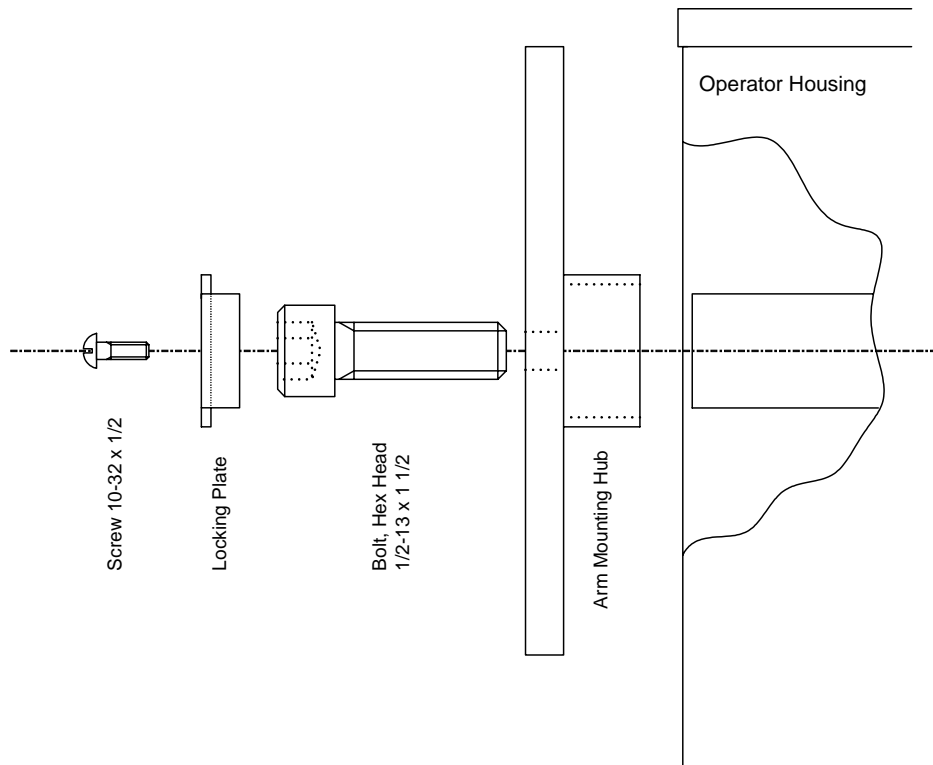

Figure 24

4.1.3 ARM INSTALLATION MODEL 1601 OPERATOR

Follow these instructions to install the barrier arm onto the 1601 operator. The illustrations below show the three different arms that can be installed on the 1601 operator; wood, plastic or aluminum. If the operator is going to be equipped with a folding arm kit for low headroom applications (wood or plastic arms only), follow the installation instructions that come with the folding arm kit.

1. Be sure that the shaft rotation has been checked as described in 4.1.1.
2. Install the arm-mounting bracket onto the arm hub using four (4) 3/8-16 x 1 1/2 hex head bolts, 3/8 lock washers and nuts. Do not tighten the bolts at this time.
3. Slide the arm between the arm hub and arm bracket.
4. Tighten the four bolts.

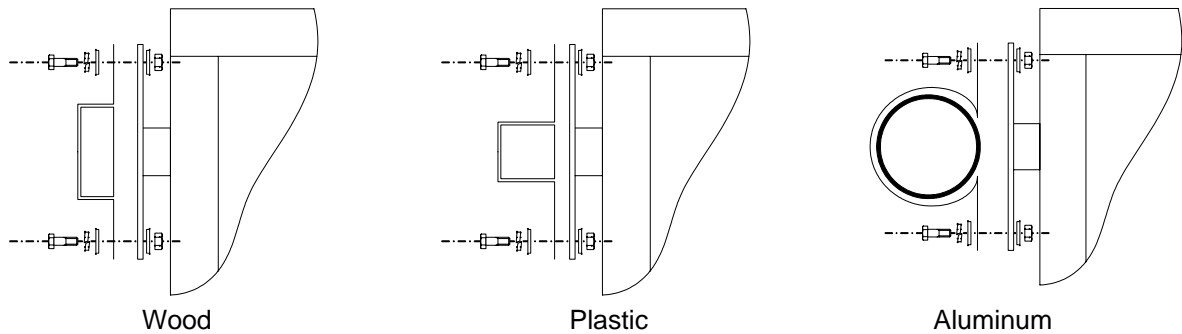

Figure 25

4.1.4 WOOD ARM INSTALLATION MODEL 1602 OPERATOR

Follow these instructions to install the 20-foot "wishbone" style wood arm onto the 1602 operator. The 1602-arm assembly consists of two sections of 1 x 4 wood 14 feet long, one section of 1 x 4 wood 10 feet long, 24 steel counterbalance plates, and necessary hardware.

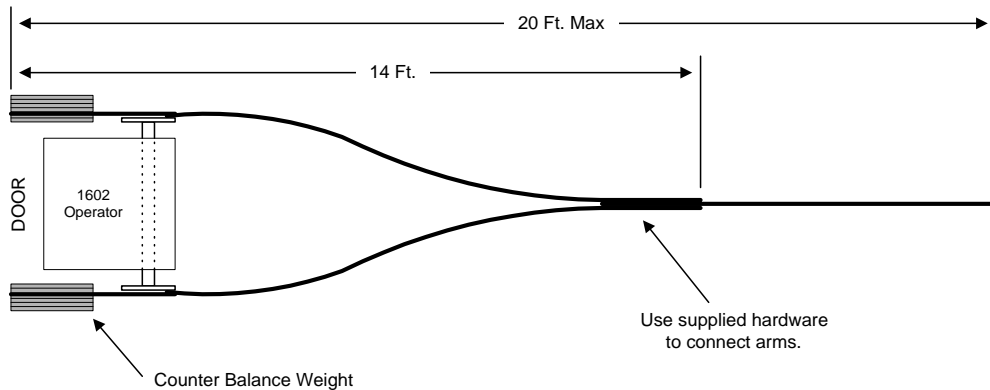

Figure 26

1. Be sure that the shaft rotation has been checked as described in 4.1.1.
2. Install the two (2) arm mounting brackets (p/n 1601-069) onto the arm hubs on each side of the operator using eight (8) 3/8-16 x 2 hex head bolts and 3/8 lock washers. Do not tighten the bolts at this time.
3. Slide the two 14 foot sections of the arm through each of the arm mounting brackets. The arms must extend at least 14 inches behind the arm hubs to allow for the counter balance plates to be installed (fig. 4.1.4B).
4. Tighten the bolts to secure the 14-foot arm sections to the arm hubs.
5. Install the 10 foot arm between the two 14 foot arms using the supplied 1/4-20 x 2 1/2 hex bolts, 1/4 USS washers, and 1/4-20 nuts.
6. Install the counterweight plates on the ends of the 14-foot arms using the supplied 5/16-18 x 3 hex bolts and 5/16-18 flange nuts. Secure the plates with six (6) sets of this hardware. Note: Place two (2) counterbalance plates on the inside of the arms, the remainder on the outside of the arms.

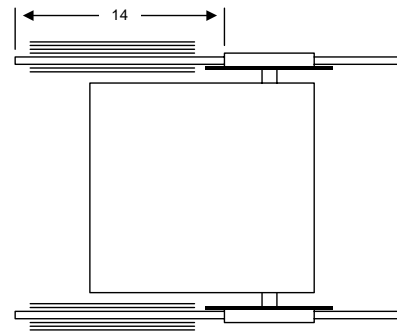

Figure 27

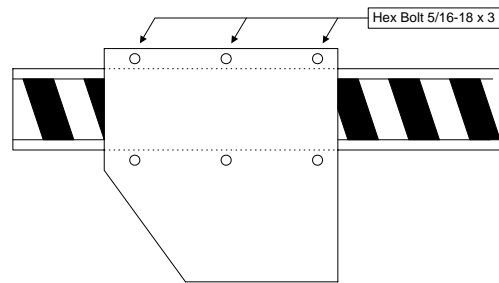

Figure 28

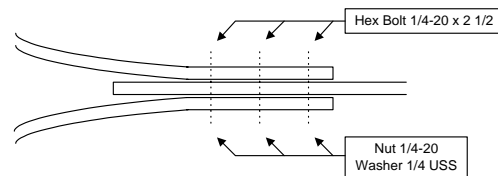

Figure 29

4.2 ACCESSORY INSTALLATION

4.2.1 REVERSING EDGE INSTALLATION

Although the 1601 and 1602 barrier gate operators are equipped with an electronic reversing device (ERD) which will reverse the travel of the arm should it come into contact with an obstruction during the down cycle, installing an optional electric reversing edge (p/n 8080-016) on the bottom of the wood arm will offer additional protection to the arm, the operator, and to the object that caused the obstruction.

If the operator is equipped with the square plastic arm (p/n 1601-071), it may not be necessary to install the reversing edge on the bottom of this arm since it is soft enough to bend out of the way should it meet an obstruction.

1. Be sure that power to the operator is OFF.
2. Attach the 6-foot mounting bracket to the bottom of the barrier arm using $\frac{3}{4}$ -inch wood screws (not supplied) at 1-foot intervals (a drill will be required to drill through the mounting bracket and into the wood arm). Position the mounting bracket so that it (the bracket) is centered in the traffic lane.
3. Slide the reversing edge into the mounting bracket being sure that the lead-in wires are on the end of the reversing edge closest to the barrier operator.
4. Route the lead-in wire along the side of the arm. It is recommended that the wire be secured to the arm with cable clamps (not supplied).
5. Drill a $\frac{1}{4}$ -inch access hole in the side of the operator cabinet beneath the operator shaft. Install a grommet in this hole to protect the lead-in wire from any sharp metal edges.
6. Route the lead-in wire through the hole drilled in step 5. Be sure to leave a loop to allow the arm to rotate without obstruction from the lead-in wire.
7. Route the lead-in wire internally so that it does not interfere with any moving mechanical linkages in the operator.
8. Connect the lead-in wires to terminals 9 and 14.

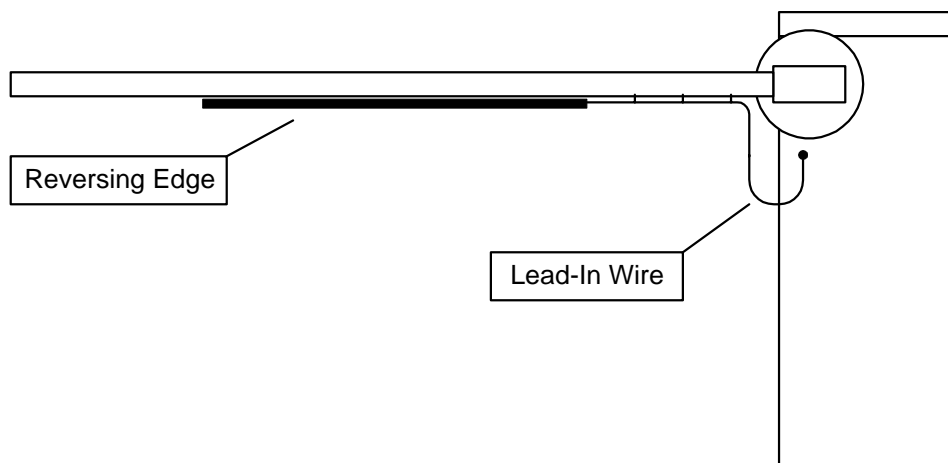

Figure 30

4.2.2 HEATER KIT INSTALLATION

The optional heater kit is recommended for usage in areas where temperatures will routinely drop below 40°F (4°C). This is necessary to keep the oil in the gearbox from freezing.

1. Be sure that power to the operator is OFF at the circuit breaker panel since connections will be made to the high voltage terminal strip.
2. Mount the heater assembly on the right inside wall of the cabinet to the mounting screws provided so that the terminal strip is positioned on the bottom. **IMPORTANT:** Be sure to place #10 washers on the mounting screws before placing the heater assembly on the screws. The washers should be between the cabinet and the heater assembly.
3. Connect the BLACK wire from the wire assembly to the 117 VAC terminal on the heater. Connect the WHITE wire to the NEUT terminal on the heater.
4. Route the wire assembly as shown below. Use the supplied cable ties to secure the wire assembly. Be sure that the wire assembly is clear of all moving parts.
5. Connect the BLACK wire to the 117 VAC terminal on the high voltage terminal block. Connect the WHITE wire to the NEUT terminal.

Switch Settings

OFF - Turns the heater off.

ON - Turns the heater on continuously. Use with caution since the heater can become very hot when running continuously.

AUTO - This is the normal setting. The heater will automatically turn on when the temperature inside the cabinet falls below 40°F, and will turn off when the temperature rises above 40°F.

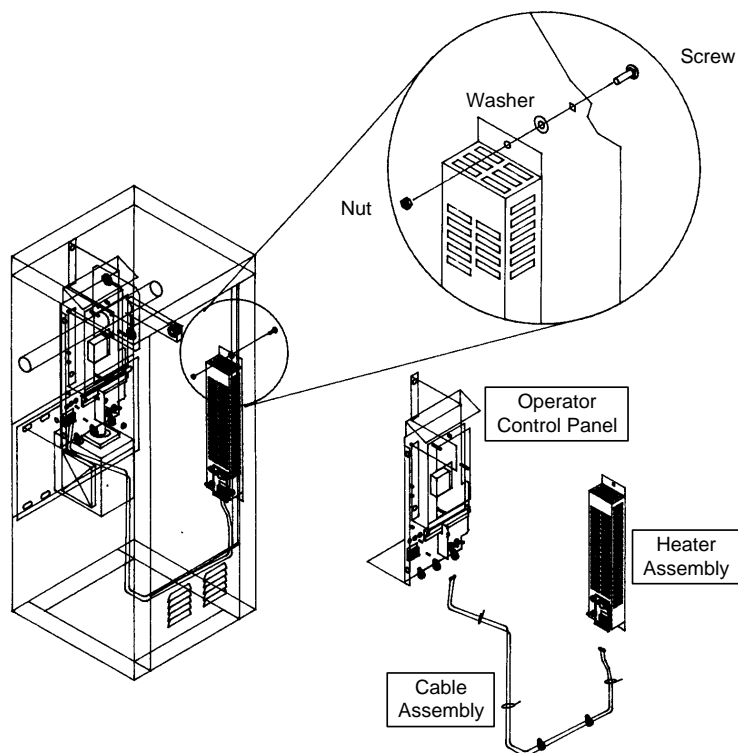

Figure 31

4.2.3 FAN KIT INSTALLATION

Use the optional fan kit in areas where hot humid climates are the norm. The fan kit prevents a build up of moisture inside the cabinet in this type of environment.

1. Be sure that power to the operator is OFF at the circuit breaker panel since connections will be made to the high voltage terminal strip.
2. Mount the fan assembly to the lower right inside wall of the cabinet to the mounting screws provided so that the terminal strip is positioned on the bottom.
3. The fan will also be secured to the duct at the bottom of the cabinet. Use the screw provided.
4. Connect the BLACK wire from the wire assembly to the 117 VAC terminal on the fan. Connect the WHITE wire to the NEUT terminal on the fan.
5. Route the wire assembly as shown below. Use the supplied cable ties to secure the wire assembly. Be sure that the wire assembly is clear of all moving parts.
6. Connect the BLACK wire to the 117 VAC terminal on the high voltage terminal block. Connect the WHITE wire to the NEUT terminal.

Switch Settings

OFF - Turns the fan off.

ON - Turns the fan on continuously.

AUTO - This is the normal setting. The fan will automatically turn on when the temperature inside the cabinet rises above 90°F, and will turn off when the temperature drops below 90°F.

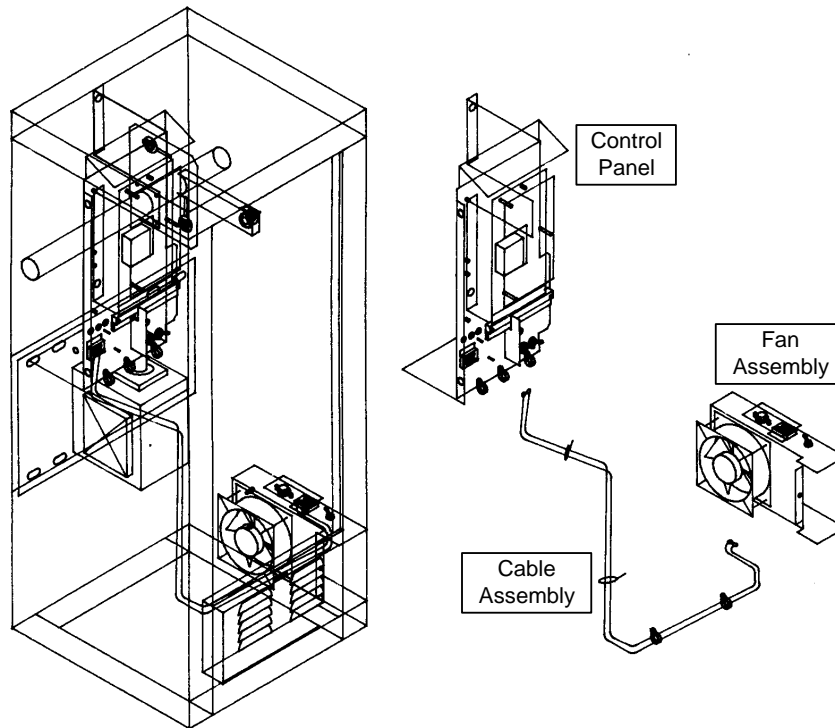

Figure 32

SECTION 5 – MAINTENANCE & TROUBLESHOOTING

5.1 MAINTENANCE SCHEDULE

MONTHLY SCHEDULE		INTERVAL		
		3	6	12
Arm	Check for cracks or weathering. Repair or replace as necessary.		✓	
Belt	Check for alignment, tightness and wear.		✓	
ERD	Check the electronic reversing device for proper operation. Adjust sensitivity if necessary.	✓		
Fire Dept.	Check emergency vehicle access device(s) for proper operation.	✓		
Gearbox	Check oil level.			✓
Linkages	Check internal linkages for wear. Inspect bushing for wear.		✓	
Loops	Check all external ground loops for proper operation.	✓		
Pulleys	Check set-screws for tightness.		✓	
Reversing Devices	Check electric edges and photo-cells for proper operation.	✓		
Complete Check	Perform a complete system check. Include all reversing devices, loops, access system devices, Fire Dept. access devices, etc.			✓

- When servicing, place AC power switch to the OFF position. If the operator is equipped with a battery back-up system, place the battery power switch to the OFF position.
- Inspection and service should be performed anytime a malfunction is observed or suspected. High cycle usage may require more frequent service checks.
- **Use only Shell OMALA 150 gear oil when adding or replacing gearbox oil. IMPORTANT: Do not fill gearbox to top. Gearbox is full when oil completely covers inspection window.**

Always check external reversing devices (loops, photo-cells, etc.) when performing maintenance. **If reversing devices are not functional and cannot be placed in an operable state, DO NOT PLACE OPERATOR IN SERVICE.** If the operator is equipped with a battery back-up system, follow the steps below to check the operation of this system.

CAUTION: Keep clear of the arm and all internal moving parts.

1. Prior to checking the battery back-up system, both the AC power switch and the battery back-up switch should be in the ON position.
2. Place the AC power switch to the OFF position. The arm should rotate to the UP position approximately two seconds after the AC power switch is shut off.
3. Turn the AC power switch to the ON position. The operator will resume normal operation.

5.2 TROUBLE SHOOTING

Have a good VOM meter to check voltages and continuity. A Meg-Ohm meter capable of checking up to 500 meg-ohms of resistance is necessary to properly check the integrity of the ground loops. When a malfunction occurs, isolate the problem to one of three areas: 1) the operator, 2) the loop system or 3) the keying devices. **Use caution when checking high voltage areas: terminals 1 through 6, the motor capacitor and the motor.**

1. Check the input indicator LEDs. They should only come ON when a keying device (card reader, push button, etc.) is activated. If any of the input LEDs are ON continuously, this will cause the operator to hold the arm up. Disconnect the keying devices one at a time until the LED goes OFF.
2. A malfunction in a loop or loop detector can cause the operator to hold open, or to not detect a vehicle when it is present over the loop. Pull the loop detector circuit boards from the loop ports on the operator circuit board. If the malfunction persists, the problem is not with the loop system. For more information on trouble shooting loops and loop detectors, refer to your loop detector instruction sheet and to the DoorKing Loop and Loop Detector Information Manual.
3. Check to be sure that there are no shorted or open control wires from the keying devices to the gate operator. If a keying device fails to raise the arm, momentarily jumper across terminals 6 and 14 on the operator circuit board. If the arm rises, this indicates that a problem exist with the keying device and is not with the operator.
4. Check the high voltage supply. A voltage drop on the supply line (usually caused by using too small supply voltage wires) will cause the operator to malfunction. Refer to the wire size chart in section 2.2.

SYMPTOM	POSSIBLE SOLUTION(S)
Operator will not run – power LED on control board is OFF.	<ul style="list-style-type: none"> • Be sure AC power switch is on. • Check for 117 VAC with a voltmeter at control board terminals 1 and 2. If voltage measures 0, check power supply to operator or check terminal strip. If voltage measures OK, replace control board.
Operator will not run – power LED on control board is ON.	<ul style="list-style-type: none"> • Momentarily jumper terminal 6 to terminal 14. If input LED does not come ON, check terminal strip or replace control board. If LED does come on, go to the next step. • Momentarily jumper terminal 2 to terminal 3 (Caution – High Voltage). The motor should run. • Momentarily jumper terminal 2 to terminal 4 (Caution – High Voltage). The motor should run in opposite direction of above. • If motor does not run in either or both steps above, bad motor, motor capacitor or wiring to motor.
Arm rotates in wrong direction.	<ul style="list-style-type: none"> • See section 4.2 to change direction of arm travel.

Arm rotates up, but will not rotate down.	<ul style="list-style-type: none"> • Check LEDs on terminals 6, 7 and 9. Any of these ON will hold the arm in the UP position. This indicates a shorted input. • Check the LEDs on the loop detectors. Any ON will hold the arm in the UP position. Possible loop or loop detector problem. • If auto timer is not used (SW1, switch 7 off), check to be sure SW1, switch 6 is in the ON position. This will cause terminal 6 to rotate the arm down when it is activated. • Check to be sure SW1, switch 4 is ON. This will cause terminal 8 activation, then deactivation to rotate arm down.
Arm rotates down, but will not rotate up.	<ul style="list-style-type: none"> • Possible direction problem. See section 4.2 to change direction of arm. After changing direction, refer to previous troubleshooting.
Arm begins to rotate down, and then changes direction.	<ul style="list-style-type: none"> • Check ERD LED. If it flashes, rotate the ERD sensitivity potentiometer counter-clockwise 1/8 turn and re-check. If ERD LED does not flash, go to next step. • Check terminal 6, 7 and 9 input LEDs for false operation. If these flash during the down movement, arm will reverse direction. • Check loop detector LEDs for false operation.
Arm rotates down, then immediately rotates up.	<ul style="list-style-type: none"> • Check terminal 6, 7, 8 and 9 input LEDs. Any turned ON can cause this problem. • Check limit LEDs. If LED does not illuminate when magnet passes by, turn power off and adjust magnet so that it is closer to the control board as it passes by.
Down input / down loop will not rotate arm to down position.	<ul style="list-style-type: none"> • Check to be sure SW1, switch 4 is in the ON position. • Down input must be activated, and then deactivated to cause arm to rotate down.
Loop detector LED is on continuously.	<ul style="list-style-type: none"> • Activate the reset switch on the loop detector. • Decrease loop detector sensitivity. • Check loop wire for resistance to ground with meg-ohm meter. Should be 100 meg-ohms or higher. If less than 50 meg-ohms, replace loop wire. • Be sure loop lead-in wire is twisted at least 6 turns per foot. • Be sure all loop connections are soldered. • Replace loop detector.
Loop detector LED never activates.	<ul style="list-style-type: none"> • Increase loop detector sensitivity. • Check continuity of loop wire. Should be 0 ohms. If continuity check indicates anything other than 0 ohms, check all connections. Replace loop wire. • Move loop detector board to the other loop detector port on the control board, and then check loop operation. If loop detector still fails, replace loop board. • If loop detector operates OK in the other loop port, replace control board.
Battery back-up system will not raise arm upon power outage.	<ul style="list-style-type: none"> • Check to be sure that the 2340-010 battery back-up control board switch settings are set as described in section 2.x. • Check that the back-up system toggle switch is in the ON position. • Check the batteries for proper voltage. Replace if necessary. • Replace the 2340-010 control board.
Arm rotates down, but will not rotate up.	<ul style="list-style-type: none"> • Possible direction problem. See section 4.2 to change direction of arm. After changing direction, refer to previous troubleshooting.

5.3 ACCESSORIES

Loop Detector	Detectors plug directly into ports on circuit board simplifying wiring. P/N 9406-010 - Single channel detector. P/N 9405-010 - Two channel detector.
Loop Wire	Loop wire with XLPE insulation is available in 500 and 1000 foot rolls. Available in Black, Blue and Red insulation.
Loop Sealant	Asphalt (P/N 2600-771) and concrete (P/N 2600-772) sealant.
Meg Ohm Meter	Checks the integrity of ground loops. P/N 9401-045
Reverse Edge	Reverse edge installs on the bottom of the wood arm. P/N 8080-016
Photo Cell	Photo cell prevents arm from lowering on vehicles or pedestrians. P/N 8080-018
Time Clock	7 day and 365 day time clocks can be used to automatically open gate at pre-set time and days. Compact clock fits inside the operator. P/N 2600-791 - 7 day clock P/N 2600-795 - 365-day clock.
Surge Devices	High and low voltage surge suppressers help prevent circuit board failure caused by lightning strikes and power surges. P/N 1876-010 - High Voltage. P/N 1878-010 - Low Voltage.
Batteries	Replacement batteries for battery back-up system. P/N 1801-009
Speed Bumps	Prefabricated 6-foot speed bump reduces traffic speed through gate system. P/N 1610-150
Heater Kit	Thermostatically controlled heater for cold weather areas. P/N 1601-092
Fan Kit	Thermostatically controlled fan for hot humid environments. P/N 1601-093
Gate Tracker™	Optional control board allows the barrier gate operator to report activity to a companion 1833, 1835, 1837 or 1838 access control system.
Wood Arm	14-foot replacement wood arm. P/N 1601-048
Aluminum Arm	14-foot replacement aluminum arm. P/N 1601-216
Plastic Arm	12-foot plastic replacement arm. P/N 1601-071
Arm Padding	Foam padding for the aluminum or wood arm. P/N 1601-211

