

THE ACTUATOR-ONE LINEAR SWING GATE OPERATOR

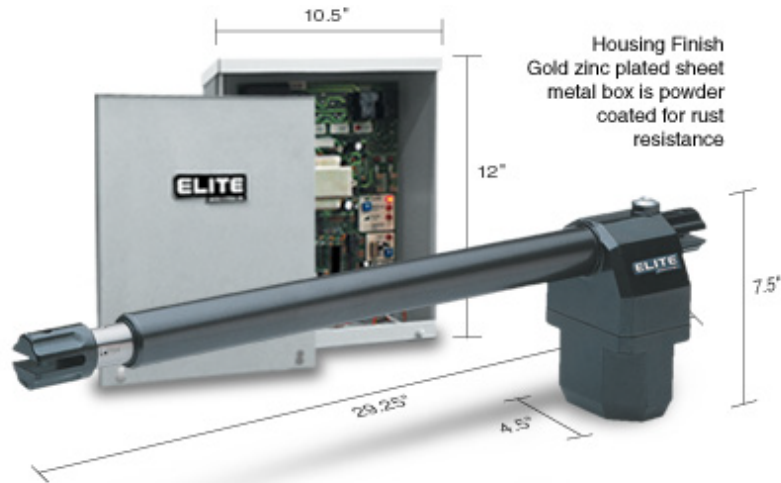

Introducing the Elite Actuator-One™, Elite's electromechanical, linear gate operator for single home use. Unlike hydraulic actuators, this unit contains no oil internally, eliminating any possibility of oil leaks. The life expectancy of this unit exceeds 1/2 million cycles. The Actuator-1™, always installed inside the property, can open to the outside as well as the inside. With 450 pounds of torque, it is capable of up to 30 complete 90 degree cycles per hour on gates up to 14 feet wide and 500 lbs. It is equipped with a burglar alarm and many other standard features not offered in other units. The Elite Actuator-One™ is competitively priced, super-quiet and reliable. It is manufactured with high quality, non-corrosive materials such as stainless steel, alloy bronze, and aluminum for years of trouble free operation.



ALARM SYSTEM

An alarm can be incorporated into the control board to alert homeowners when the gate is forced open.



PHOTOCELL

To avoid injury, Elite highly recommends the installation of a photocell sensor as a secondary means of protection.



MAGLOCKS

A Magnetic Lock System can be incorporated into the control board for higher security.



KEY RELEASE

In case of an emergency, the gate can be operated manually by using the convenient key release.



POSITIVE STOP

Heavy-duty, positive stops are available and recommended for safe and reliable operation.



ACTUATOR ONE

Design and specifications subject to change without notice.

THE ACTUATOR-ONE LINEAR SWING GATE OPERATOR

ELECTRICAL SPECIFICATIONS

RUNNING SYSTEM:

Microcontroller with built-in watchdog system.

MODULAR BOARD:

Uses LEDs to indicate all input and output functions.

SENSOR: Causes the gate to stop when it makes contact with a vehicle while opening or closing. The transmitter will reverse the gate.

TIMER:

Can be set from 3 to 60 seconds, or "push-open/stop/close" operation.

MASTER/SLAVE:

Dictates synchronized movement between two gate operators.

HOUSING FINISH: Entire housing is gold-zinc plated and powder coated.

ALARM OUTPUT:

Can be interfaced with any home alarm system. Alarm will sound if the gate is forced open. Optional siren can be installed.

SPIKE SUPPRESSORS:

System is equipped with LCR filter and spike suppressors for protection.

INPUTS AND OUTPUTS:

Master/Slave, alarm system, magnetic lock interface, radio receiver, full control system "push-open/stop/close", safety loop, photocell, telephone entry, and key switch.

CONTROL BOARD HOUSING DIM.:

Length 10.5" Width 4.25" - Height 12"

SAFETY LOOP INPUT:

Anti-tailgating system uses a "stop only" method of operation. This input will not work as a commercial loop system.

MECHANICAL SPECIFICATIONS

INSTALLATION:

Can be installed two ways: Open inside Close outside or Open outside Close inside.

CYCLES:

30 complete 90 degree cycles per hour with ambient temperature of 90° f

DIMENSIONS:

L(open) 44.5"(closed) 29.25" x H 7.5" x W 4.5"

FINISHING:

Aluminum die-cast body with epoxy paint and stainless steel shaft for excellent corrosion resistance.

MOTOR

120VAC, 3 amp auto reset system

CAPABILITIES:

Max gate size 14', 500 lbs.

TORQUE:

450 lbs. of torque

SHIPPING WEIGHT:

Single 27 lbs M/S 44 lbs

OUTPUT SHAFT:

1.25" stainless steel shaft

TRAVEL SPEED: 18 to 21 seconds

to 90°

TWO YEAR WARRANTY

Elite Access Systems, Inc., warrants the Actuator-One™ gate operating system to be free of defects in workmanship and material for a period of two years from the date of purchase. This warranty does not cover battery or other external accessories.

