

INSTALLATION AND OPERATION INSTRUCTIONS
FOR THE
MASTER/SLAVE SYSTEM
OF X1 SERIES GATE OPERATORS
(- 73 BOARD)

TABLE OF CONTENTS

SAFETY SUMMARY	1
BASIC INSTALLATION HINTS AND RULES	2
PART 1 MASTER/SLAVE OPERATION	3
A. WHAT IS MASTER/SLAVE OPERATION?	3
B. MASTER/SLAVE GATE CONFIGURATIONS	3
C. MASTER/SLAVE INSTALLATION DETAILS	4
PART 2 MASTER/SLAVE LAYOUTS AND WIRING	10
A. CONNECTING INPUT WIRING	10
B. MASTER/SLAVE INTERCONNECTION	11
C. SYSTEM CONTROL WIRING AND SET UP	12
D. SYSTEM LAYOUTS AND CONTROL WIRING	13
E. TROUBLESHOOTING	26
NOTICE TO CANADIAN USERS	27

TABLE OF FIGURES

Figure 1. Master/Slave Gate Configurations.	3
Figure 2. Typical Bi-Parting Gate Installation.	4
Figure 3. Typical Bi-Parting Latch Gate Installation.	5
Figure 4. Typical Trap Gate Installation.	6
Figure 5. Typical Tandem Gate Installation.....	8
Figure 6. Control Board Wiring.	10
Figure 7. Master/Slave Connection.....	12
Figure 8. Bi-Part, Bi-Directional Gate System.....	13
Figure 9. Bi-Part, Uni-Directional Gate System (Swing gate, if used, opens in).....	13
Figure 10. Bi-Part, Uni-Directional Gate System (Swing gate opens out).....	14
Figure 11. Bi-Part, Bi-Directional Gate System.	14
Figure 12. Bi-Part Latch, Uni-Direction Gate System (Swing gate, if used, opens in).....	15
Figure 13. Bi-Part Latch, Uni-Directional Gate System (Swing gate opens out).	15
Figure 14. Bi-Directional Trap Gate System (Swing Gate, if used, opens in).	16
Figure 15. Bi-Directional Trap Gate System (Swing gate opens out).	17
Figure 16. Uni-Directional Trap Gate System (internal Swing gate, if used, opens in).	18
Figure 17. Uni-Directional Trap Gate System (internal Swing gate opens out).....	19
Figure 18. Uni-Directional Trap Gate System (external Swing gate, if used, opens in).	20
Figure 19. Uni-Directional Trap Gate System (external Swing gate opens out).....	21
Figure 20. Bi-Directional Tandem Gate System (Swing gate, if used, opens in).	22
Figure 21. Bi-Directional Tandem Gate System (Swing gate opens out).....	23
Figure 22. Uni-Directional Tandem Gate System (Swing gate, if used, opens in).	24
Figure 23. Uni-Directional Tandem Gate System (Swing gate opens out).....	25

In the interest of better serving its customers, Sentex is constantly in the process of upgrading its products. Consequently, Sentex reserves the right to make changes in the products described in this manual without notice and without obligation of Sentex to notify any persons of any such revisions or changes. Additionally, Sentex makes no representations of warranties with respect to this manual. This document is protected by copyright, and may not be copied or adapted without the prior written consent of Sentex Systems. This document contains information proprietary to Sentex and such information may not be distributed without the prior written consent of Sentex. The firmware included in the Sentex model SL 1000-X1, SW 2000-X1, BG 3000-X1 and BG 3100-X1 Gate Operators as they relate to this documentation is also protected by copyright and contain information proprietary to Sentex.

Copyright © 2000
All Right Reserved

Sentex Systems
Chatsworth, CA

Visit us at www.sentexsystems.com

SAFETY SUMMARY

It is important for everyone involved in the installation and operation of the Sentex Gate Operator models SL 1000, 2000, 3000, and 3100-X1 Master/Slave systems to read the following warnings.

WARNING!

- A vehicle gate is a large, heavy object that is moved by an electric motor. A moving gate can cause serious injury or death! The safety and well-being of others depends on the installation of a safe system.
- Improper installation of a gate operator can result in a dangerous system.
- Gate operators can present serious hazards to persons in the immediate area when not controlled in a safe manner. Choose one or more controls which together will allow complete control of the gate. Most importantly, the gate must be able to be stopped at all times in case of emergency, and the emergency control should be conveniently located, clearly marked, and visible.
- All controls must be kept out of reach of small children. Serious injury or death can result from children playing with the controls.
- All controls should be located so the person operating them can see the full area of gate movement.
- Gate operators and associated control equipment should be installed by qualified professional installers who should observe the following safe installation procedures:
 1. Power should always be disconnected whenever installing, wiring, or servicing a gate operator. Moving chains and belts in gate operators can catch clothing or fingers and cause severe injury.
 2. Installation of wiring should comply with all local building and electrical codes.
 3. All manual gate locks should be disabled to avoid damage to the gate or gate operator should the lock become engaged after the operator is installed.
 4. All operator controls and safety equipment should be tested at the conclusion of installation to be sure they are functioning properly.
 5. The operation of the gate controls and safety equipment should be reviewed with the owner and/or end user of the automated gate system. They should also be informed of the need to maintain control and safety equipment on a regular basis. Safety equipment should be checked monthly to ensure it is working properly. All installation manuals and safety information should be left with the owner.
 6. Moving gates have pinch points and entrapment zones which can be extremely dangerous to pedestrians, especially small children.

BASIC INSTALLATION HINTS AND RULES

PLEASE READ THIS SECTION CAREFULLY BEFORE BEGINNING YOUR INSTALLATION. The sections that follow contain detailed procedures for the installation of Gate Operator models SL 1000, 2000, 3000, and 3100-X1 Master/Slave systems. In addition to these specific procedures, there are a number of general hints and rules which will help ensure that your installation will be done correctly and efficiently. These are discussed below.

1. **UNDERSTAND THE SYSTEM AND INSTALLATION SITE THOROUGHLY.** The X1 Gate Operator series are flexible and reliable gate operator systems, but the quality of service depends directly on the quality of installation. Please read these instructions and the Installation and Operation instructions for each gate operator carefully. Study the applicable diagrams before planning your installation. In particular, understand any site characteristics that may affect the system installation.

WARNING

2. **INSTALL PERMANENT WIRING.** U.L. specifications require the X1 Series Master/Slave systems to be permanently wired. Refer to your local wiring code for specific information.

WARNING: Damage caused by faulty wiring is not covered by warranty.

3. **GROUND THE SYSTEM.** The system contains parts which may be damaged by static discharge. A proper earth ground connected to the gate operator housing will significantly reduce the chances of damage or improper operation. The shielding in the cables specified for all remote sensors and controls should also be connected to earth ground at the controller end of the cable only.

To be effective, the ground connection must be made by running 12 AWG copper wire to a good ground point (e.g., an electrical panel, a metallic cold water pipe that runs into the earth, or a grounding rod at least 10 feet in length that is driven into the earth) within 12 feet of the system. Even if you have a good ground, you should try to discharge any static before handling the circuit boards.

WARNING: Damage caused by static discharge and lightning is not covered by warranty.

4. **PROVIDE POWER FROM A DEDICATED SOURCE.** The outlet into which you connect the Gate Operators should be wired to its own circuit breaker. This will reduce the line noise introduced into system power and minimize the risk of having other equipment interrupt system operation. In a Master/Slave system, Master and Slave must each have separate circuits.
5. **DO NOT OVERLOAD THE TERMINAL BLOCKS.** The terminal blocks used in the gate operator are removable and the pins are soldered into the boards. To connect the wires, remove the "head" from the correct terminals and open the screws. Insert the wire into the correct opening on the front and tighten the screw until the wire is held firmly. When you have made all connections for a given "head", plug it back onto the pins designated for that terminal block.

Stranded wire must be between 16 and 24 AWG. Solid wire must be between 18 and 24 AWG. This is the total thickness measurement so, if you are putting two wires in, the combined thickness must fall within this range. **NEVER** try to insert more than two wires per terminal.

6. **ENSURE GOOD CONNECTIONS.** A light tug on the wire will tell you if the connection is secure. When reconnecting system components, make sure all pins are straight on chips, connectors, and terminal block heads.
7. **READ MARKINGS CAREFULLY.** The connection points are marked on the boards clearly. Before making any connection, be sure to read the marking and check it against the corresponding figure in these instructions so that you understand the connection you are making.
8. **TRAIN YOUR CUSTOMERS THOROUGHLY.** Although customer responsibility is limited to proper installation, the quality of service is determined by the care of system set up. Ensure that the customer has a copy of this manual to guide them. It will save you and them lots of inconvenience and aggravation later.

PART 1

MASTER/SLAVE OPERATION

A. WHAT IS MASTER/SLAVE OPERATION?

The easy way to understand master/slave operation is by the computer terms “smart” and “dumb”.

- “Smart” machines are controlled by a computer or dedicated microprocessor, such as microwave ovens and new-style washing machines.
- “Dumb” machines are controlled by simple electronic or physical mechanisms, like old-style washing machines with their cams and timers.

When your installation requires using two gates together, they can be controlled either by the “dumb” method of wiring them in parallel and using limit cams and reclose timers for control (see the Installation and Operation manual for the individual gate operators), or the “smart” method of enabling the Master/Slave programming built into the gate operators.

Sentex gate operators are capable of handling any gate combination you’re likely to need, and we strongly recommend using the “smart” method for the following reasons:

1. **Synchronization:** Gate actions (opening, closing, etc.) are synchronized in Master/Slave operation.
2. **Added safety:** A fault in one unit affects both units, providing added safety to the system.
3. **Reduced wiring:** Inputs (radio, exit loops, etc.) need be wired to only one unit in some Master/Slave configurations.
4. **Simplified gate setting:** Gate controls (ATG, Reclose Timer, etc.) only need to be set in one unit in some Master/Slave configurations.

Let’s take a quick look at some Master/Slave gate configurations, cover the wiring and setup procedures, then go into the details of each type to help plan your installation.

B. MASTER/SLAVE GATE CONFIGURATIONS

Sentex models SL 1000-X1 (slide gate), SW 2000-X1 (swing gate), BG 3000-X1 (barrier gate), and BG 3100-X1 (barrier gate) can be teamed as Master/Slave systems in the following configurations:

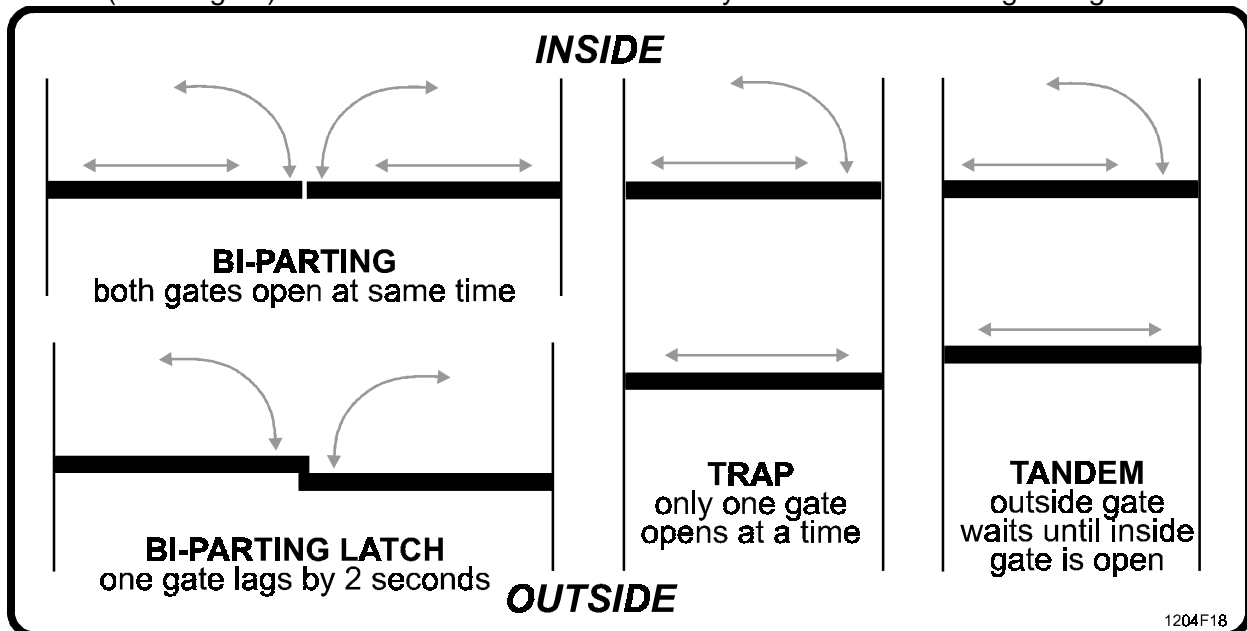

Figure 1. Master/Slave Gate Configurations.

- In the Master/Slave configuration, one Master unit controls one Slave unit.
- Master and Slave units communicate at 9600 baud via a 4-wire interconnection cable.

C. MASTER/SLAVE INSTALLATION DETAILS

1. BI-PARTING GATE DETAILS

The simple Bi-Parting Gate is typically used in low traffic residential sites due to its ease of use. The Bi-Parting configuration can consist of any combination of models SL 1000-X1 (slide gate), SW 2000-X1 (swing gate), BG 3000-X1 (barrier gate) and BG 3100-X1 (barrier gate).

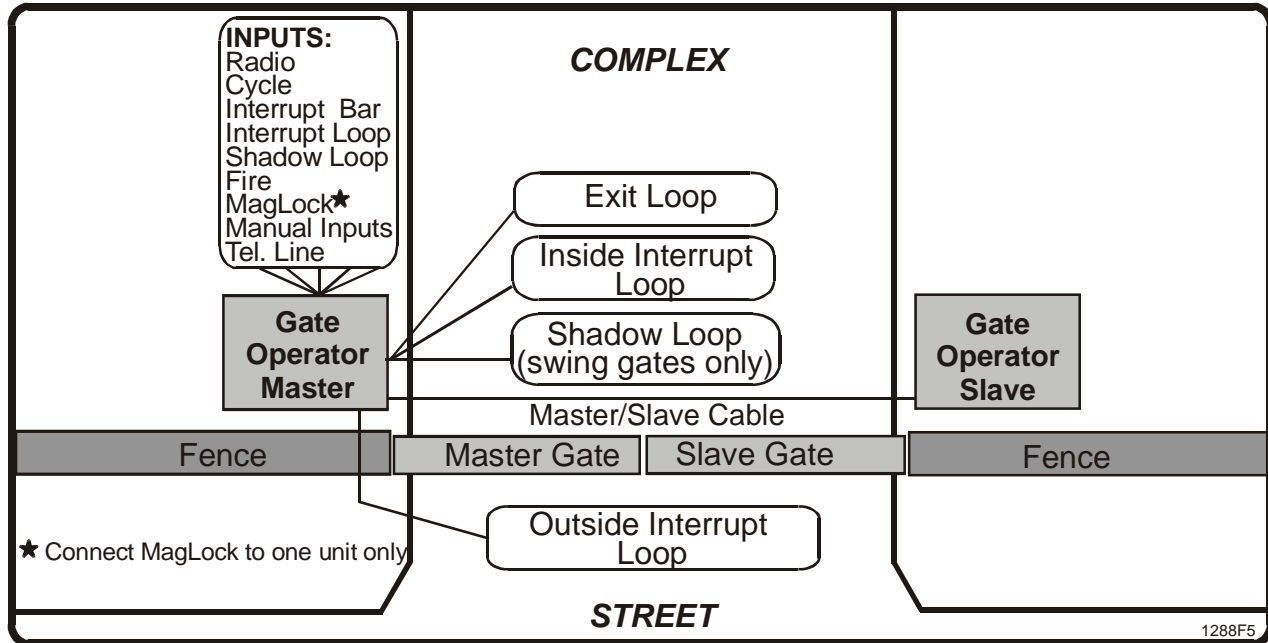

Figure 2. Typical Bi-Parting Gate Installation.

HOW IT WORKS:

- The gates in a Bi-Parting configuration are mirror images of each other and act identically.
- A Fault in one unit affects both units (see Troubleshooting/Maintenance for Fault List in the Installation and Operation manual for the individual gate).
- A Continuous FIRE input in either gate opens the gates and holds them open.

There are 3 different ways to close the gates (entering or exiting):

1. Reclose Timer: When the Reclose Timer expires, gates close automatically.
2. ATG (Anti-Tailgate) and Interrupt Loop: With ATG ON, clearing the Inside Interrupt Loop closes the gates.
3. Alternate Action: With ATG and TIMER OFF, a Radio or CYCLE command will close fully open gates.

INPUT CONNECTIONS: Refer to Part 2, Master/Slave Layout and Wiring, for more details.

- Inputs can be connected to either gate. Inputs (Interrupt Bar, Interrupt Loops, Shadow Loop) may be connected to both gates to enhance safety.
- The telephone line is connected to the Master Unit only.

NOTE: See the Gate Operator Programming manual to program gate functions.

2. BI-PARTING LATCH GATE DETAILS

The Bi-Parting Latch Gate is typically used in low traffic residential sites due to ease of use and added security of magnetic locking. The Bi-Parting Latch configuration can consist of any combination of models SL 1000-X1 (slide gate), SW 2000-X1 (swing gate), BG 3000-X1 (barrier gate) and BG 3100-X1 (barrier gate).

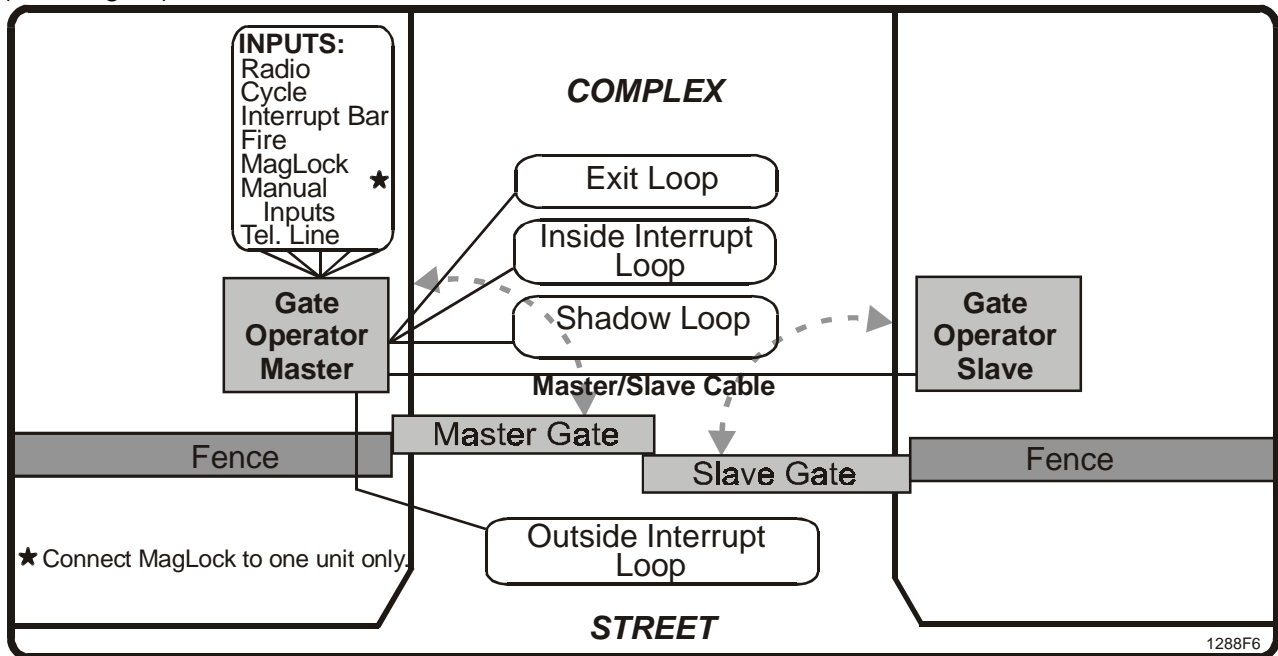

Figure 3. Typical Bi-Parting Latch Gate Installation.

HOW IT WORKS:

- The Master moves first during opening and Slave first during closing, with a 2 second delay between them to prevent gate intercollision and to ensure proper latching. When the gates are fully closed, the outer edge of the Master gate rests on the outer edge of the Slave gate.
- A fault in one unit affects both units (see Troubleshooting/Maintenance for Fault List in the Installation and Operation manual for the individual gate).
- A continuous FIRE input in either gate opens the gates and holds them open.

There are 3 different ways to close the gates (entering or exiting):

1. Reclose Timer: When the Reclose Timer expires, gates close automatically.
2. ATG (Anti-Tailgate) and Interrupt Loop: With ATG ON, clearing the Inside Interrupt Loop closes the gates.
3. Alternate Action: With ATG and TIMER OFF, a RADIO or CYCLE command will close the fully open gates.

WARNING: The Power Fail Operation Option can be used **only** on the Master Unit. To maintain all gate functions during power outages, use a full UPS (Uninterruptable Power Supply) on each unit.

INPUT CONNECTIONS: Refer to Part 2, Master/Slave Layout and Wiring, for more details.

- Inputs can be connected to either gate. Inputs (Interrupt Bar, Interrupts Loops, Shadow Loop) may be connected to both gates to enhance safety.
- The telephone line is connected to the Master unit only.

NOTE: See the Gate Operator Programming manual to program gate functions.

3. TRAP GATE DETAILS

The Trap gate is typically used in secured sites for screening incoming and/or outgoing traffic. In the Trap configuration, only one gate opens at a time, “trapping” the vehicle between gates. Due to its ease of use, Slide Gates are the most popular for the Trap configuration. The Trap configuration can consist of any Sentex model for the Master, and a model SL 1000-X1 (slide gate), BG 3000-X1 (barrier gate) or BG 3100-X1 (barrier gate) for the Slave. NOTE: The SW 2000-X1 (swing gate) may not be used for the Slave gate.

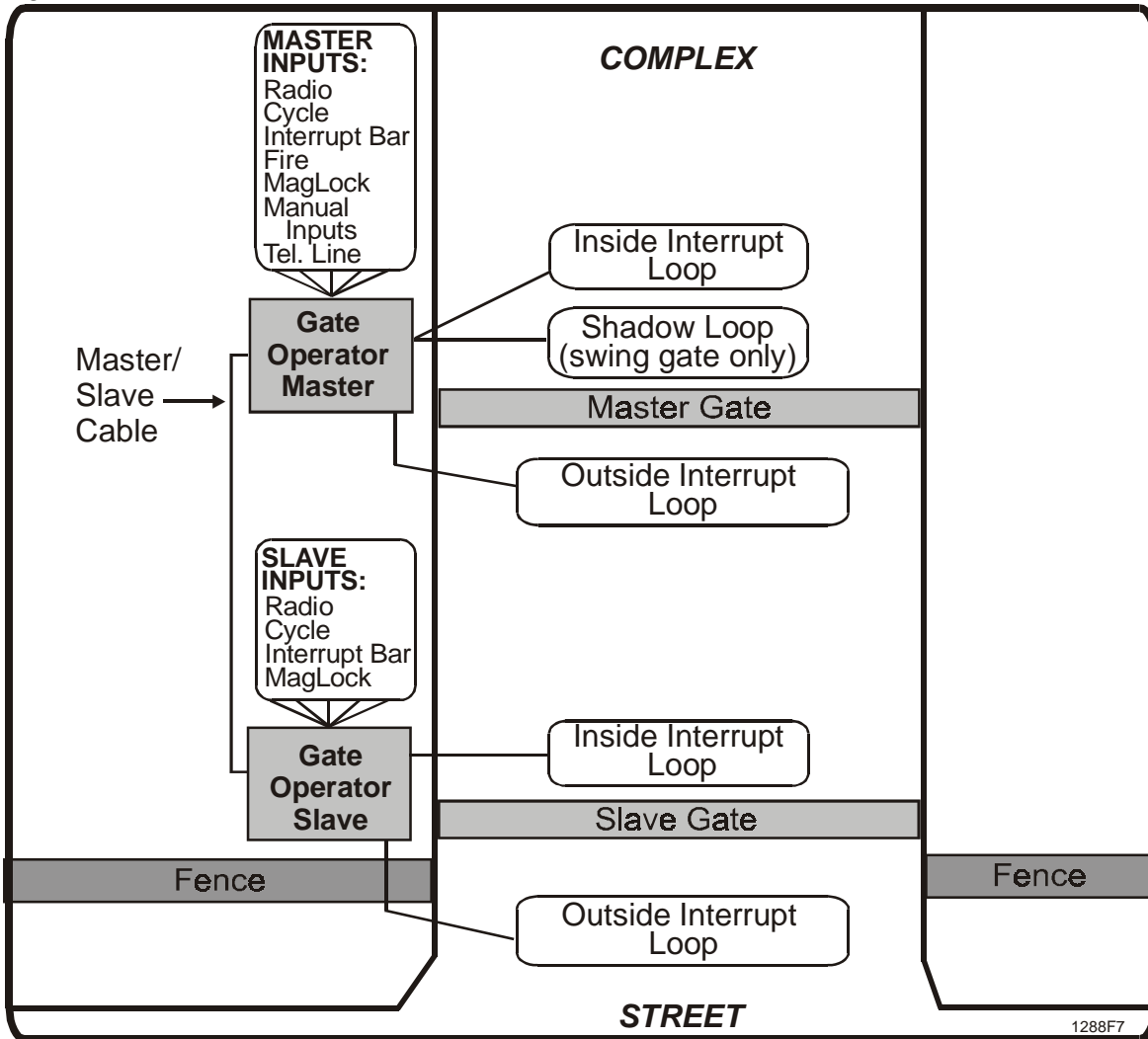

Figure 4. Typical Trap Gate Installation.

HOW IT WORKS

- In normal operation, one gate must completely close before the other opens, so only one gate is open at a time. As soon as one gate closes, the second gate automatically opens. If the second gate does not open within 10 seconds, the first gate reopens to let the vehicle exit the trap area.
- A continuous FIRE or Manual OPEN input in either gate opens the gates and holds them open.
- If a vehicle stalls between the gates and they close, they can be opened by a CYCLE or RADIO command, or by driving over the Slave unit Inside Interrupt Loop (Gate Type = Slide or Barrier only).

There are 2 different ways to close the gate (entering or exiting):

1. Reclose Timer: When the Reclose Timer expires, gate closes automatically (Master or Slave).
2. ATG (Anti-Tailgate) and Interrupt Loop: With ATG enabled, clearing the Interrupt Loops causes the gates to close (Master or Slave).

NOTE: To ensure gate closure, enable Reclose Timer (make sure Reclose Time \neq 0) in both Master and Slave units.

INPUT CONNECTIONS: Refer to Part 2 Master/Slave Layout and Wiring, for more details

- Master and Slave units require their own separate inputs except Manual inputs or FIRE, which can be connected either unit.
- If Radio inputs are used in both units, each requires its own transmitter and entry code.
- The telephone line is connected to the Master unit only.

NOTE: See the Gate Operator Programming manual to program gate functions.

4. TANDEM GATE DETAILS

The Tandem gate is typically used in high traffic situations where some control of incoming and/or outgoing traffic is required. The outside gate is usually a less expensive fast moving barrier gate (or light slide gate) which protects the more expensive and less mobile Slide or Swing inside gate. The outside gate does this by stopping the vehicle until the inside gate is completely open. The Tandem configuration can consist of any Sentex model for Master, and a model SL 1000-X1 (slide gate), BG 3000-X1 (barrier gate) or SG3100-X1 (barrier gate) for Slave. NOTE: The SW 2000-X1 (swing gate) may not be used for Slave.

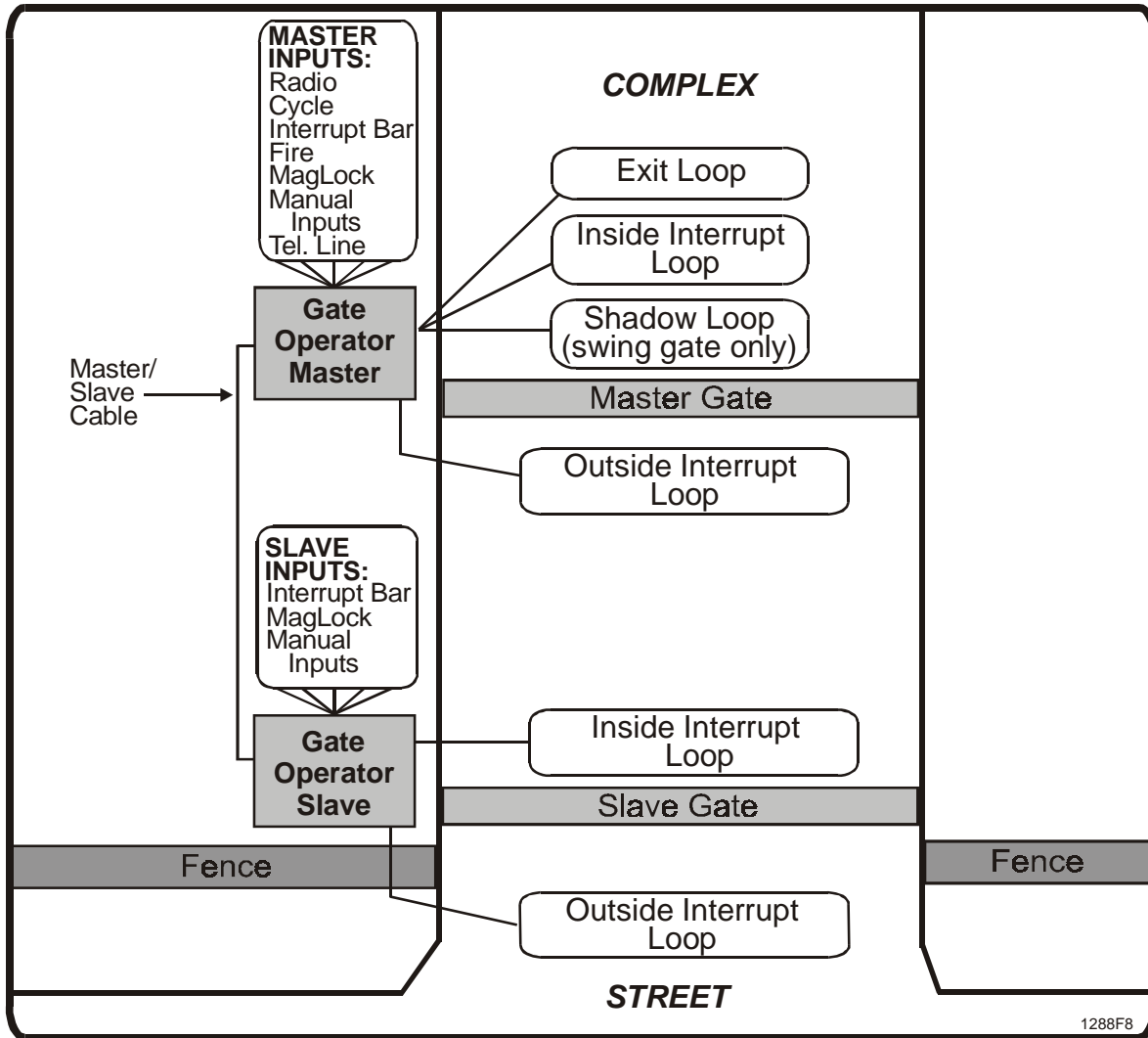

Figure 5. Typical Tandem Gate Installation.

HOW IT WORKS:

- When a vehicle is entering or exiting, the inside Master gate opens first. When the Master is completely open, the outside Slave gate opens, allowing the vehicle to enter or exit. If ATG or Reclose Timer is enabled, the Master gate cannot initiate closing until the Slave gate is fully closed.
- During high traffic hours, the slower-moving Master gate can be latched open by a continuous Manual Open input, leaving the faster moving Slave gate to control entering and exiting traffic.
- If a vehicle stalls between the gates and they close, either can be opened by a CYCLE or RADIO command, or by driving over the Slave unit Inside Interrupt Loop (Gate Type = Slide or Barrier only).
- A continuous FIRE input in either gate opens both gates and holds them open.
- A continuous Manual STOP in either gate stops both gates.

There are 2 different ways to close the gate after entering or exiting:

1. Reclose Timer: When the Reclose Timer expires, the gates close automatically (first the Slave gate, then the Master gate).
2. ATG (Anti-Tailgate) and Interrupt Loop: With ATG enabled, clearing the Inside Interrupt Loop causes the gate to close (Master or Slave).

INPUT CONNECTIONS: Refer to Part 2 Master/Slave Layout and Wiring, for more details.

- Radio, Cycle, Exit, Manual Stop or Fire inputs can be connected to either unit.
- The telephone line is connected to the Master unit only.

NOTE: See the Gate Operator Programming manual to program gate functions.

PART 2 MASTER/SLAVE LAYOUTS AND WIRING

A. CONNECTING INPUT WIRING

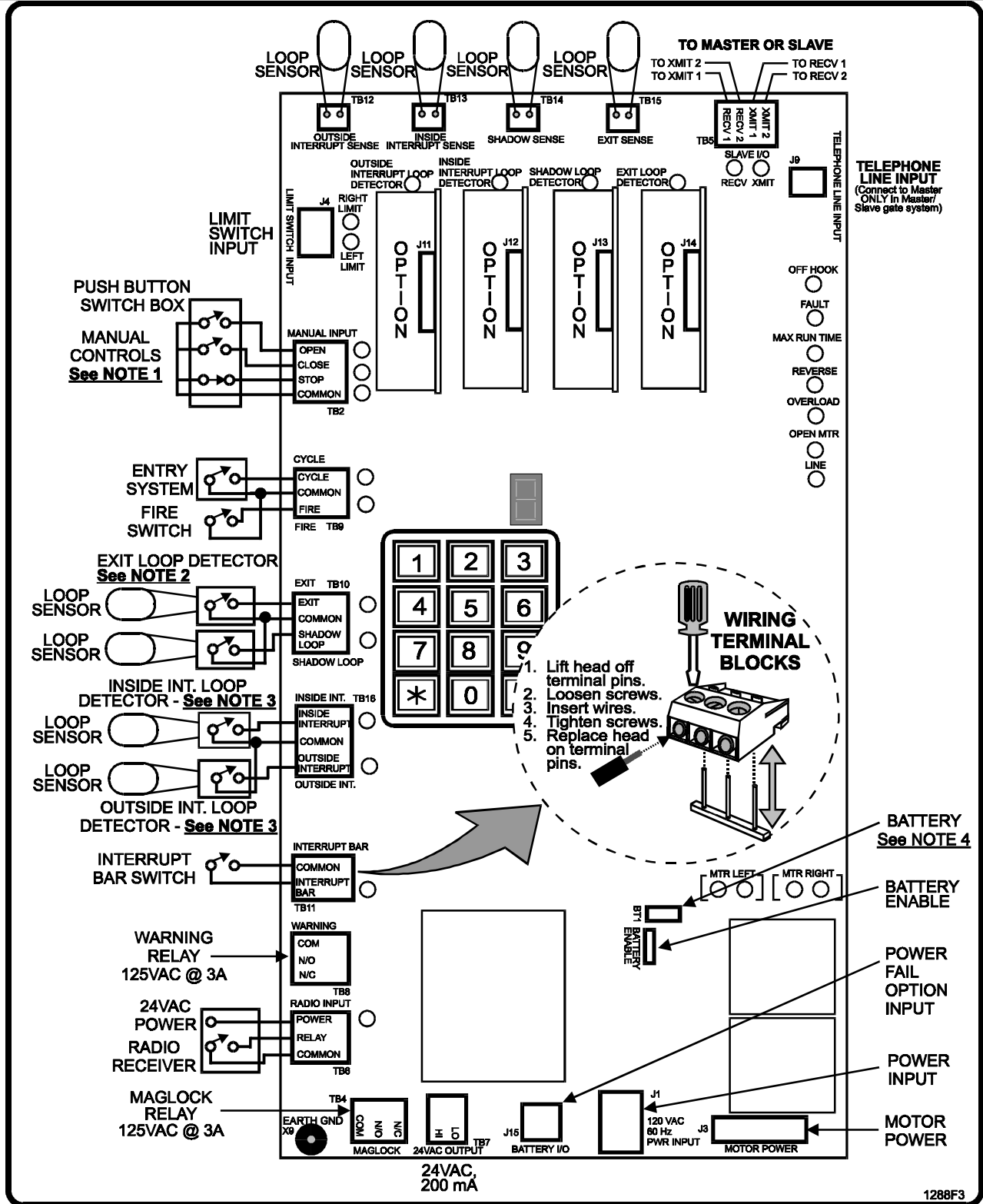

Figure 6. Control Board Wiring.

IMPORTANT

Before proceeding, see NOTES on the next page.

NOTES

1. Disconnecting the STOP terminal from the COMMON terminal stops the gate and prevents all commands from having any effect. Manual Open does not activate the Reclose Timer.
2. If gate(s) are used for bi-directional traffic, the Exit Loop should be a directional loop detector.
3. Inside and Outside Interrupt Loops:
 - ◆ For maximum safety, Inside and Outside Interrupt loops require separate loop detectors.
 - ◆ If only one loop detector is used, the Outside loop must also be connected to the Inside loop detector.
 - ◆ To enhance system safety in Bi-Parting and Bi-Parting Latch Master/Slave systems, the Interrupt loops, Shadow loops and Interrupt Bar switches may be connected to both gates. If this is done, when connecting the two control boards, *do not interchange input and common terminals*. If terminals are interchanged inputs will not be detected and controller boards may be damaged.
4. If AC power to the controller board is cut off, the battery will retain the correct time and date.

INPUT WIRING

Slave I/O Input (TB5) Input/output terminals are used for communication between Master and Slave gate operators.

INDICATORS

XMIT Indicates data is being sent to the other gate operator (Master or Slave).
RECV Indicates data is being received from the other gate operator (Master or Slave).

B. MASTER/SLAVE INTERCONNECTION

- A conduit between the Master and Slave units should be provided for the Master/Slave interconnection cable.
- Two shielded twisted pair wire 16 AWG to 24 AWG will be connected between the two units at TB5 on the controller board.

NOTES: 1. Do not run the Master/Slave cable and AC power wires in the same conduit.
2. Master/Slave interconnection cable should not exceed 3000 feet in length.

C. SYSTEM CONTROL WIRING AND SET UP

1. Select the desired gate layout in Section D.
2. Be sure to turn off BOTH gate operator units.
3. Wire all external control devices to their connections on the control board shown. See the Installation and Operation instructions for the gate operators, Appendix A for details on how each control input affects the gate operator.
4. Connect the Master/Slave interconnect cable: connect the Receive inputs (RECV1, RECV2) on each board to the Transmit inputs (XMIT1, XMIT2) on the other board (see Figure 7).
5. Turn on power to the Slave gate operator.
6. Turn on power to the Master gate operator.
7. Perform the Basic Gate Operator Programming, Post Assembly Procedure, and Final Assembly of Gate Operator instructions, as found in Part 2 of the Installation and Operation instructions for the gate operators.

NOTE: If the Master/Slave connection is broken, one of the units is turned off, or one of the controller boards malfunctions, the system will not operate.

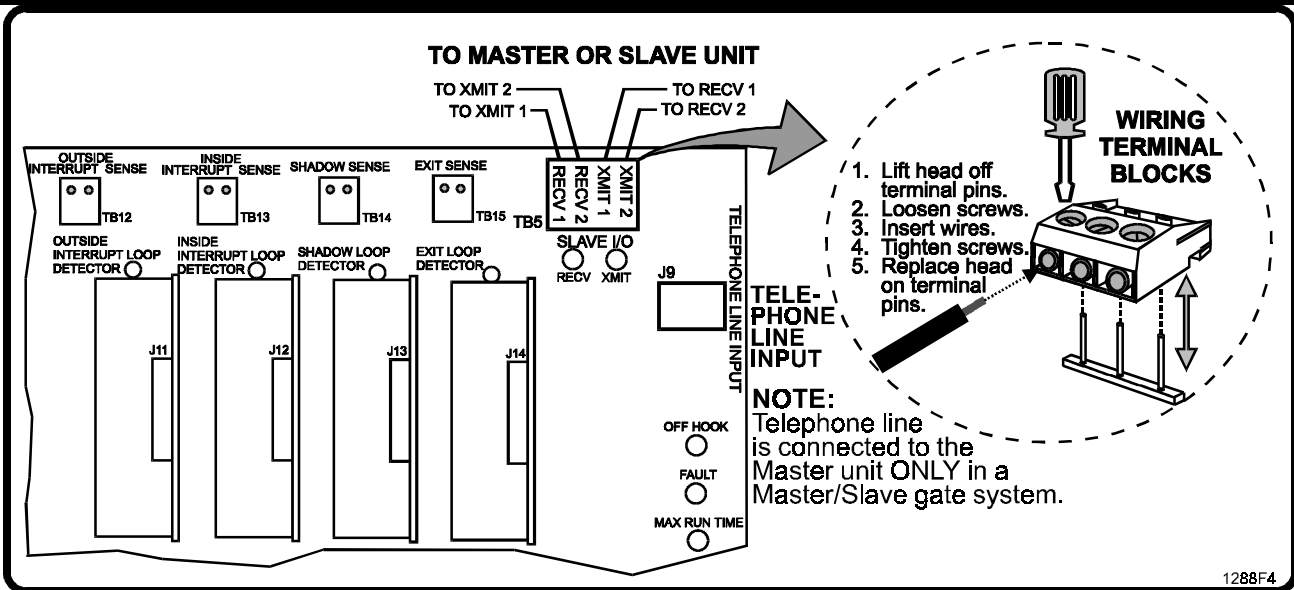

Figure 7. Master/Slave Connection.

D. SYSTEM LAYOUTS AND CONTROL WIRING

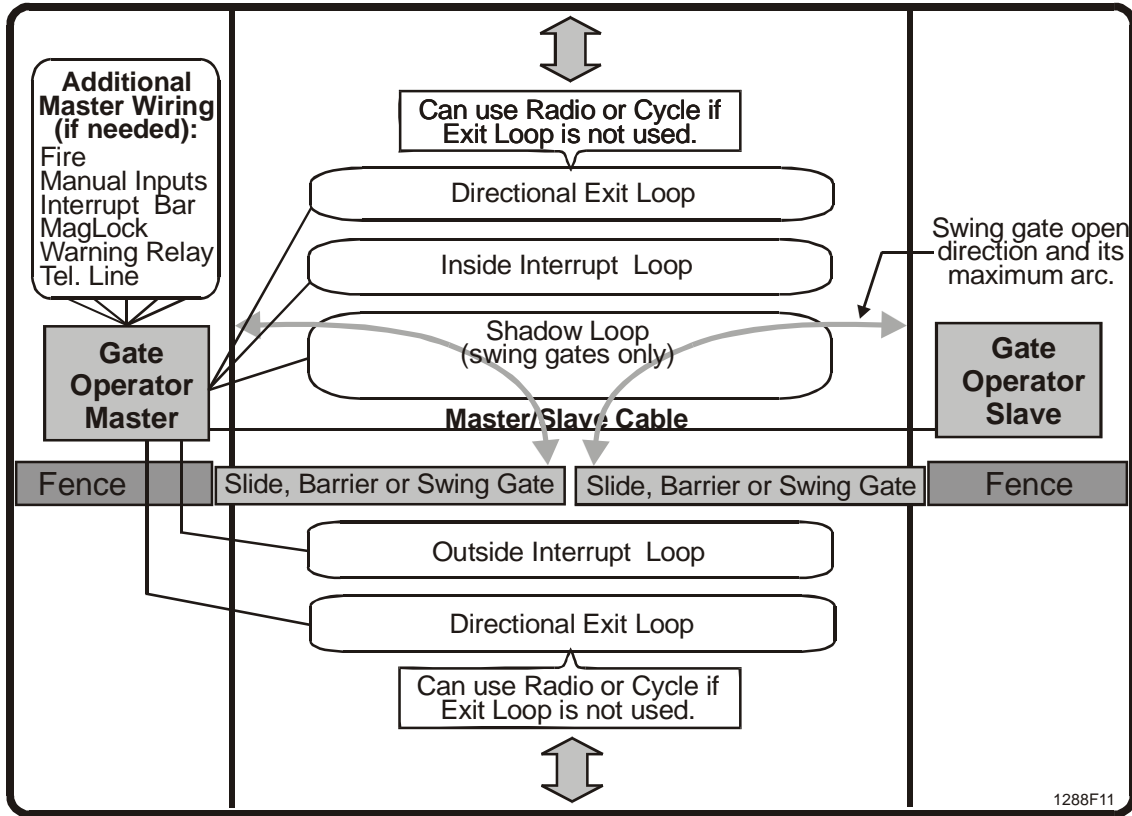

Figure 8. Bi-Part, Bi-Directional Gate System.

NOTE: If Radio is used, only one receiver/transmitter is required for both directions.

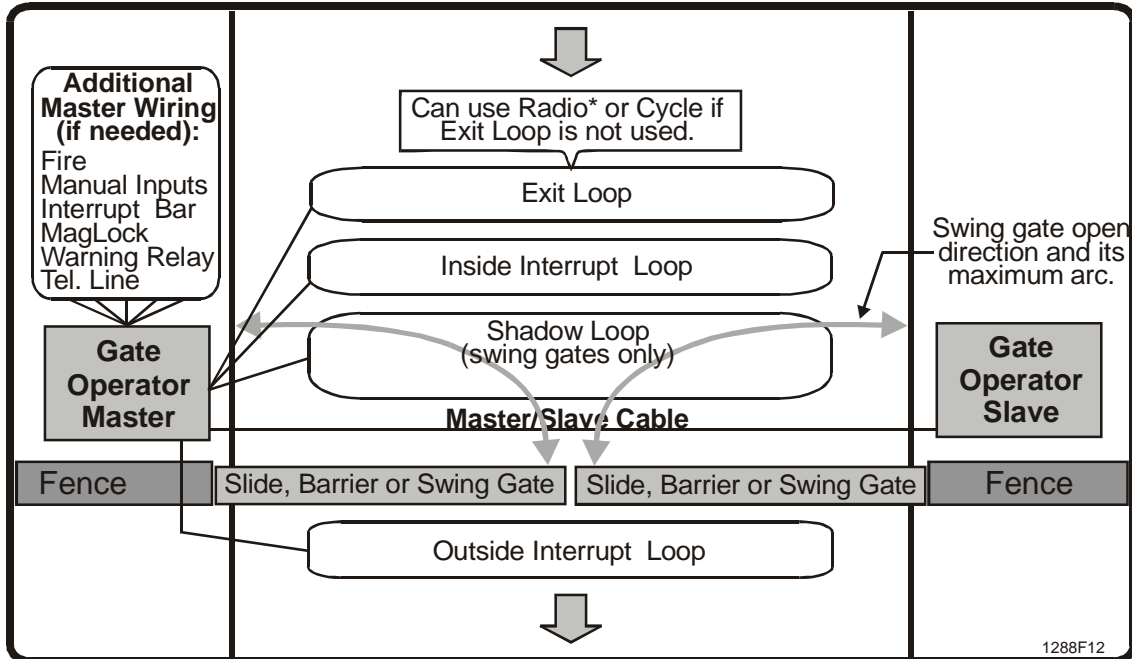

Figure 9. Bi-Part, Uni-Directional Gate System (Swing gate, if used, opens in).

*** WARNING**

If Radio is used, gate system becomes bi-directional, compromising safety and security.

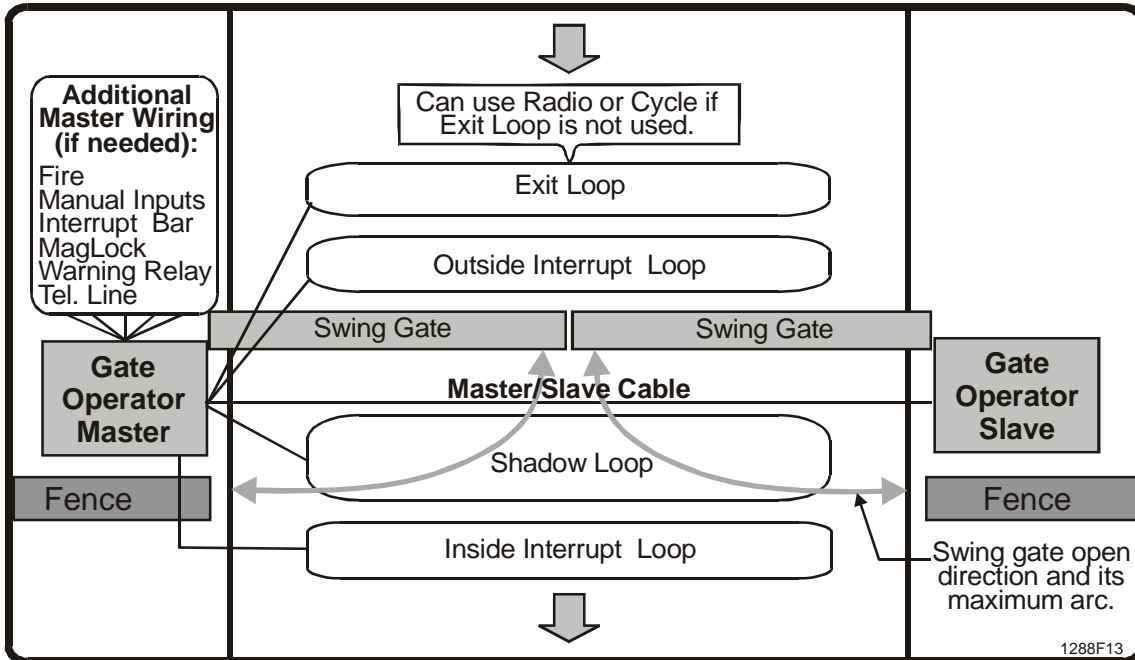

Figure 10. Bi-Part, Uni-Directional Gate System (Swing gate opens out).

*** WARNING**

If Radio is used, gate system becomes bi-directional, compromising safety and security.

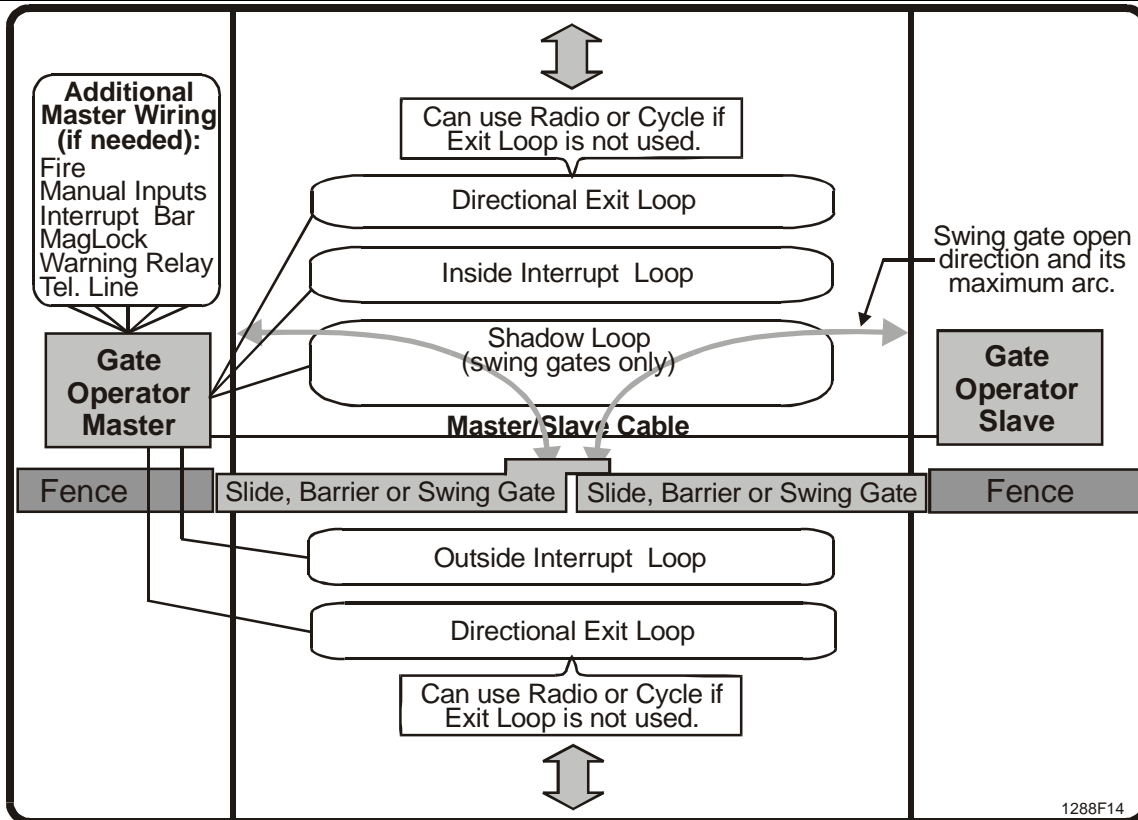

Figure 11. Bi-Part, Bi-Directional Gate System.

NOTE: If Radio is used, only one receiver/transmitter is required for both directions.

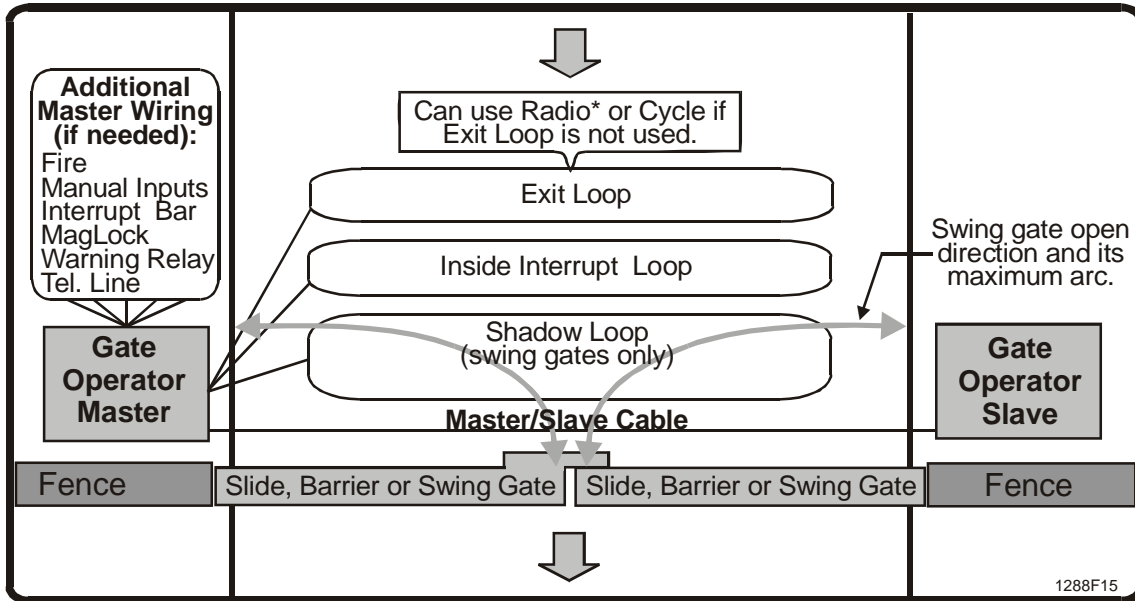

Figure 12. Bi-Part Latch, Uni-Direction Gate System (Swing gate, if used, opens in).

*** WARNING**

If Radio is used, gate system becomes bi-directional, compromising safety and security.

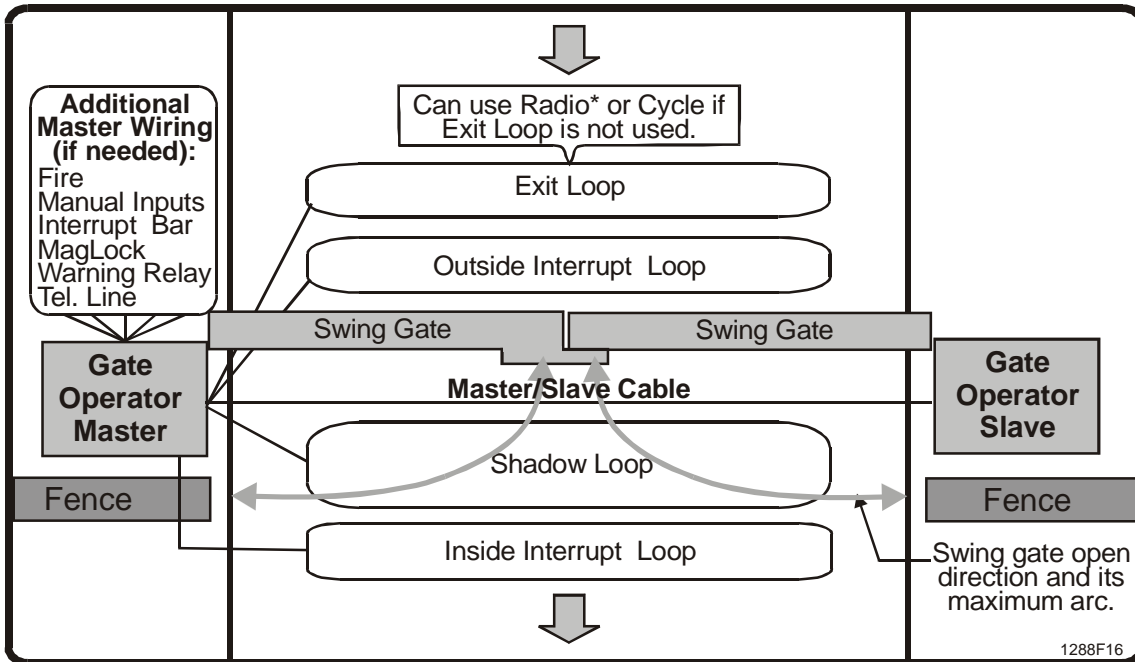

Figure 13. Bi-Part Latch, Uni-Directional Gate System (Swing gate opens out).

*** WARNING**

If Radio is used, gate system becomes bi-directional, compromising safety and security.

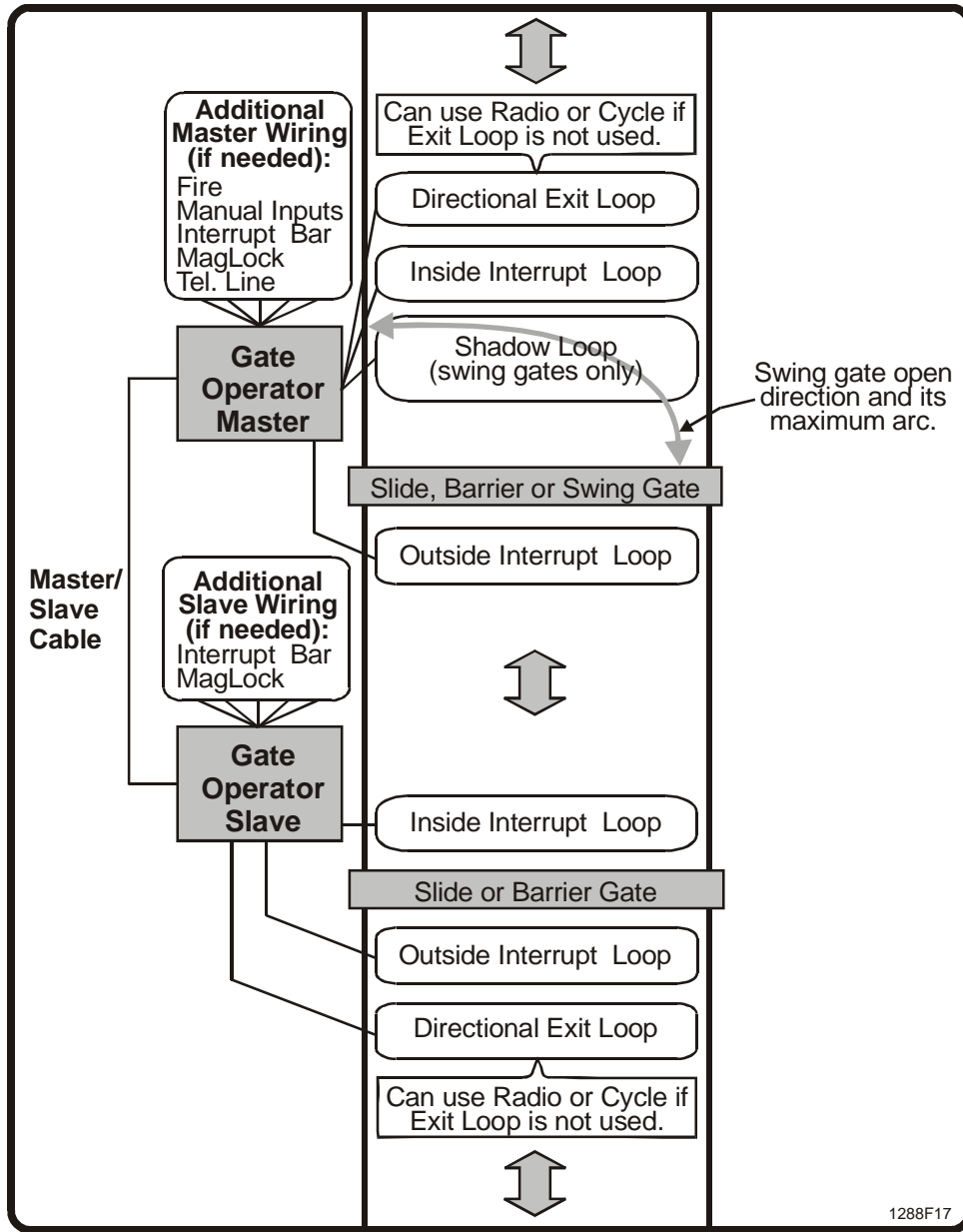
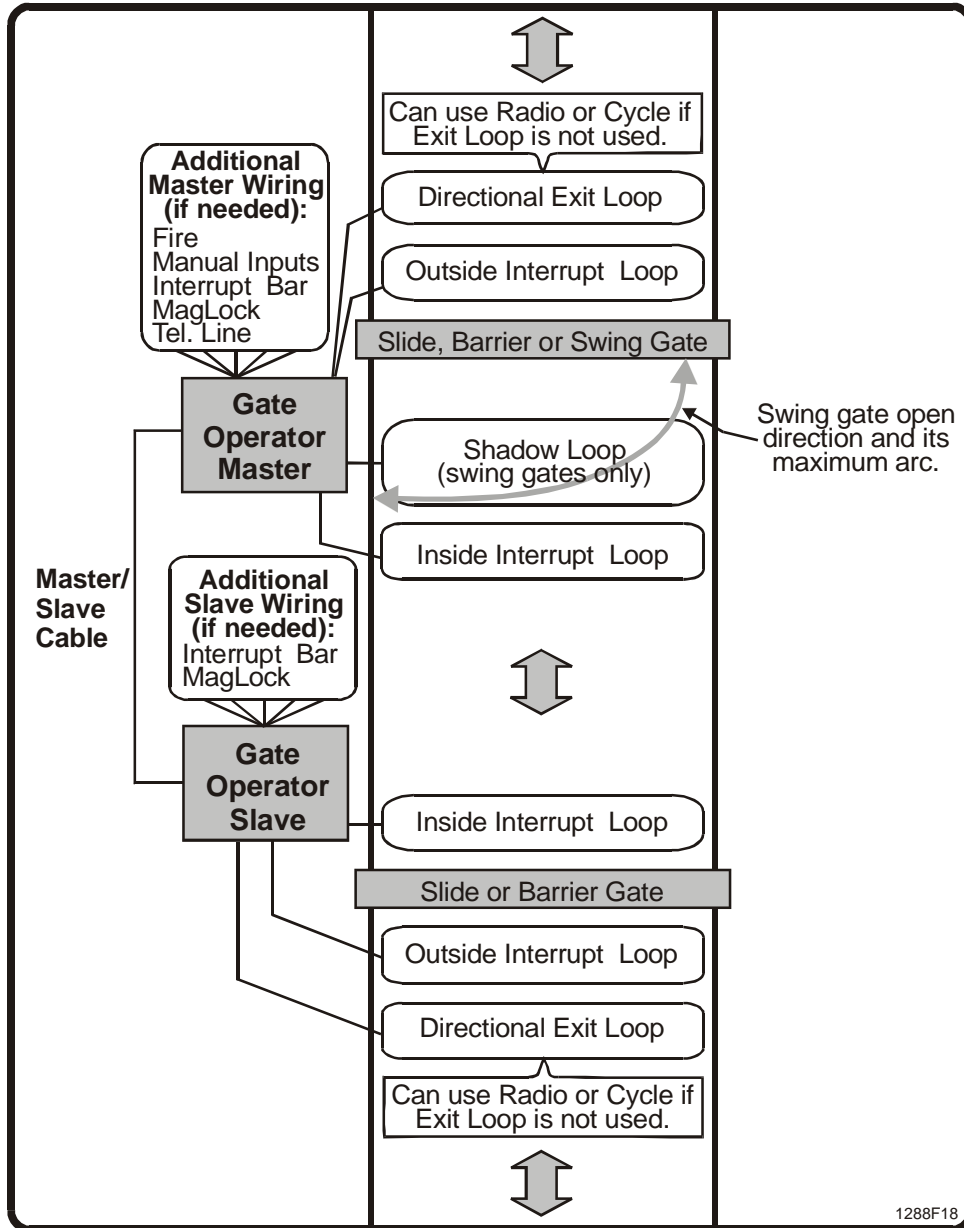

Figure 14. Bi-Directional Trap Gate System (Swing Gate, if used, opens in).

NOTE: If Radio will be used in both gates, each gate will require a separate receiver/transmitter with a separate entry code.



**Figure 15. Bi-Directional Trap Gate System
(Swing gate opens out).**

NOTE: If Radio will be used in both gates, each gate will require a separate receiver/transmitter with a separate entry code.

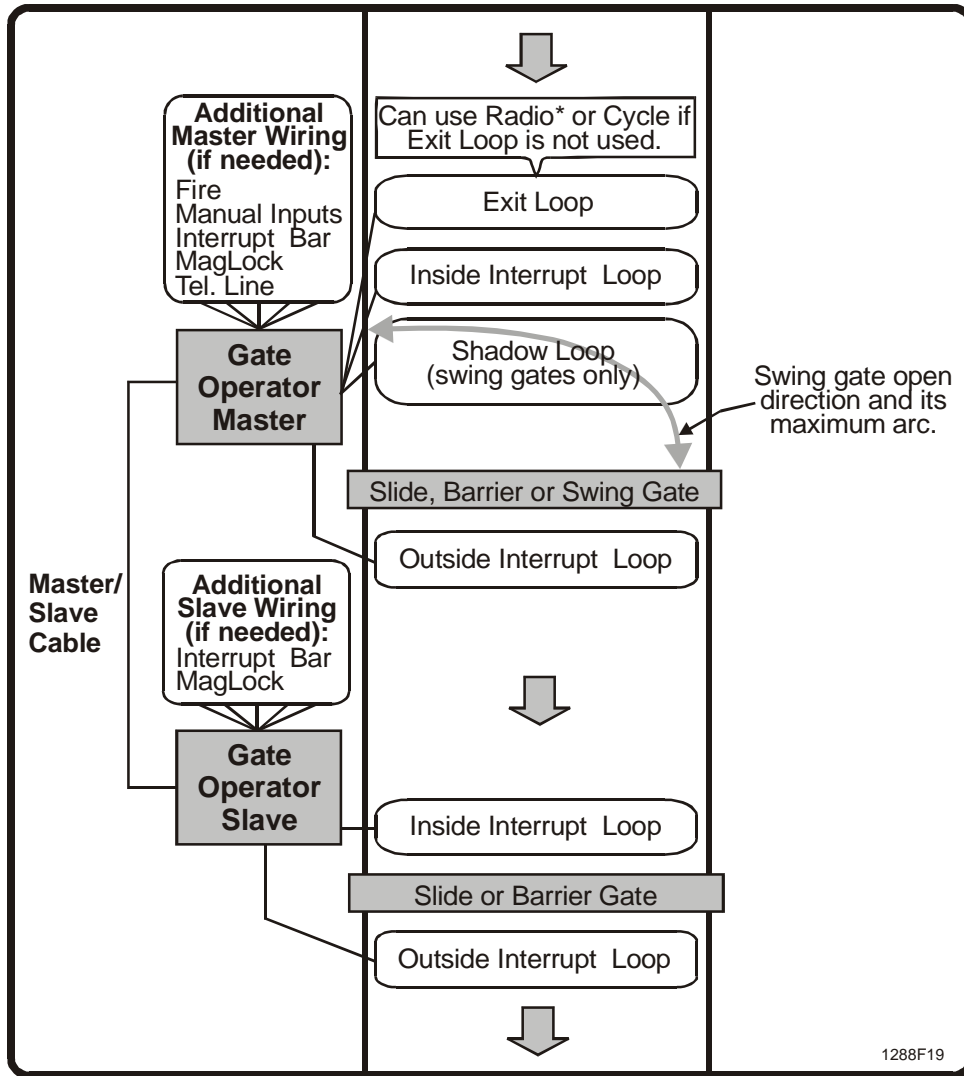
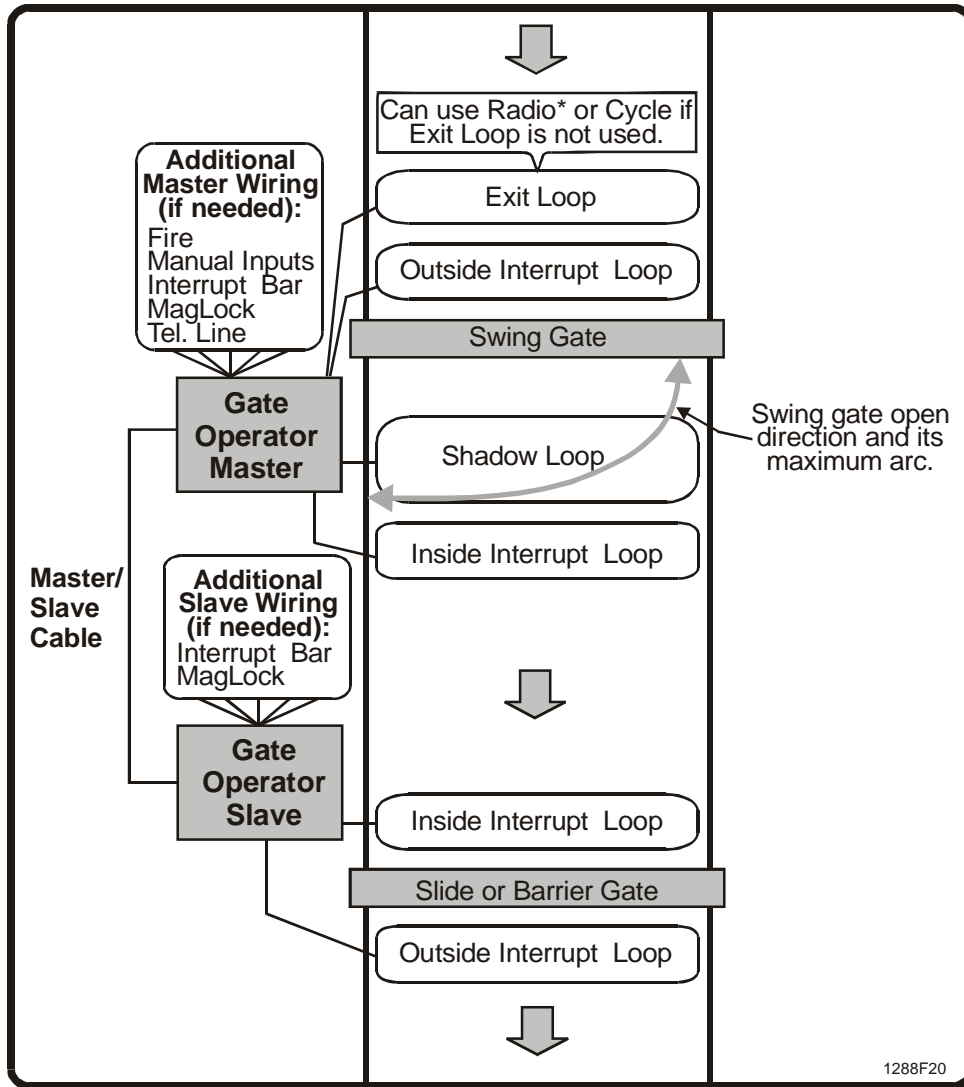

Figure 16. Uni-Directional Trap Gate System (internal Swing gate, if used, opens in).

*** WARNING**

If Radio is used, gate system becomes bi-directional, compromising safety and security.



**Figure 17. Uni-Directional Trap Gate System
(internal Swing gate opens out).**

*** WARNING**

If Radio is used, gate system becomes bi-directional, compromising safety and security.

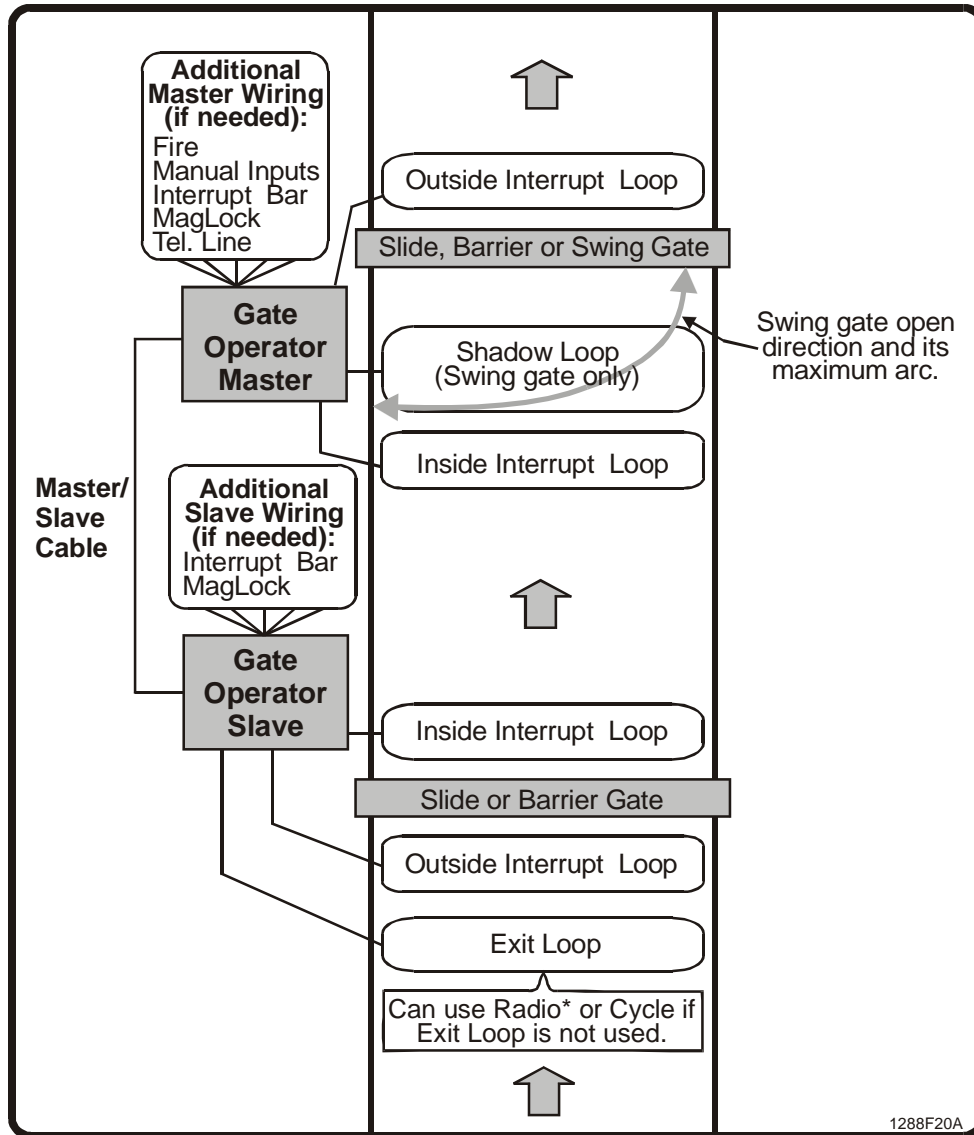

**Figure 18. Uni-Directional Trap Gate System
(external Swing gate, if used, opens in).**

*** WARNING**

If Radio is used, gate system becomes bi-directional, compromising safety and security.

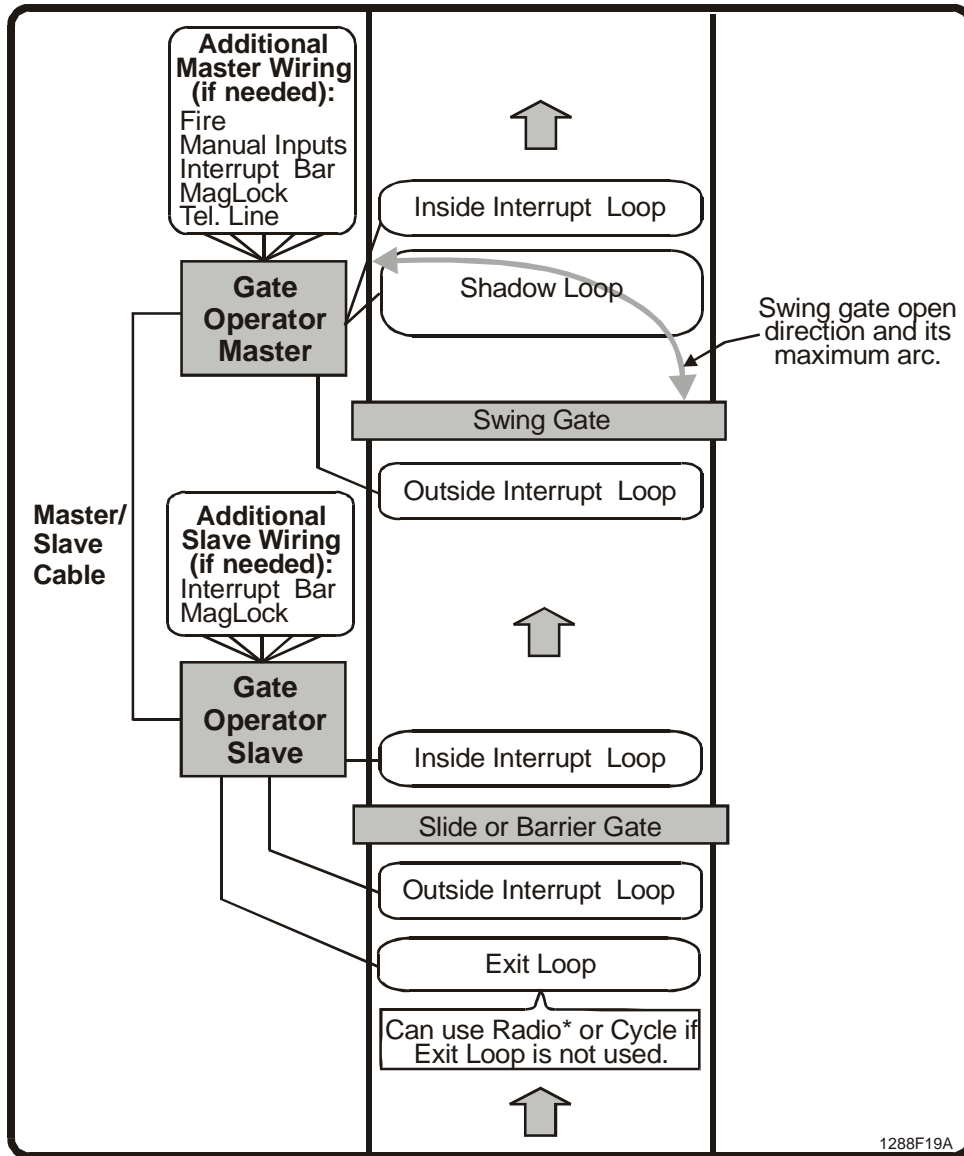

**Figure 19. Uni-Directional Trap Gate System
(external Swing gate opens out).**

*** WARNING**

If Radio is used, gate system becomes bi-directional, compromising safety and security.

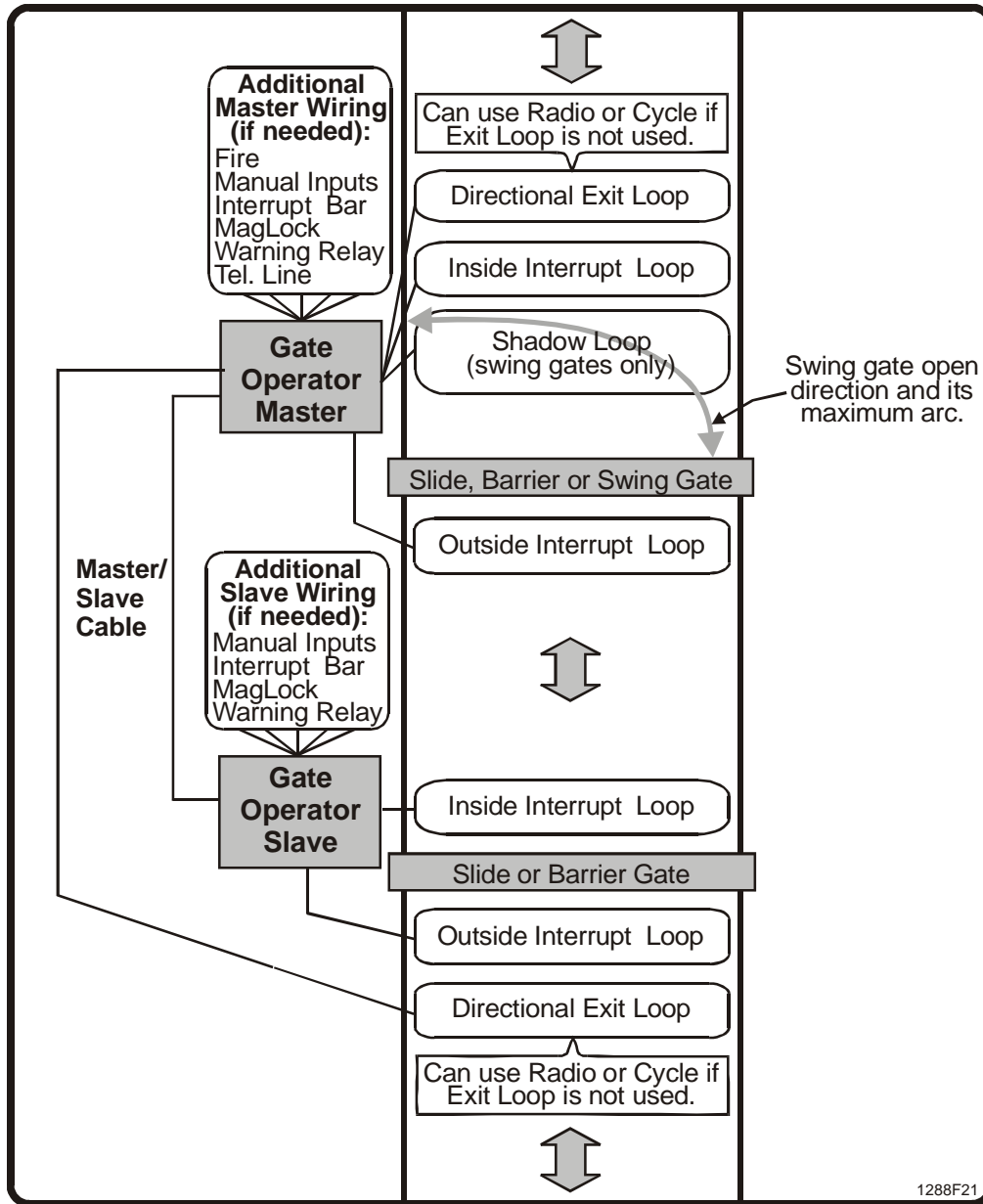
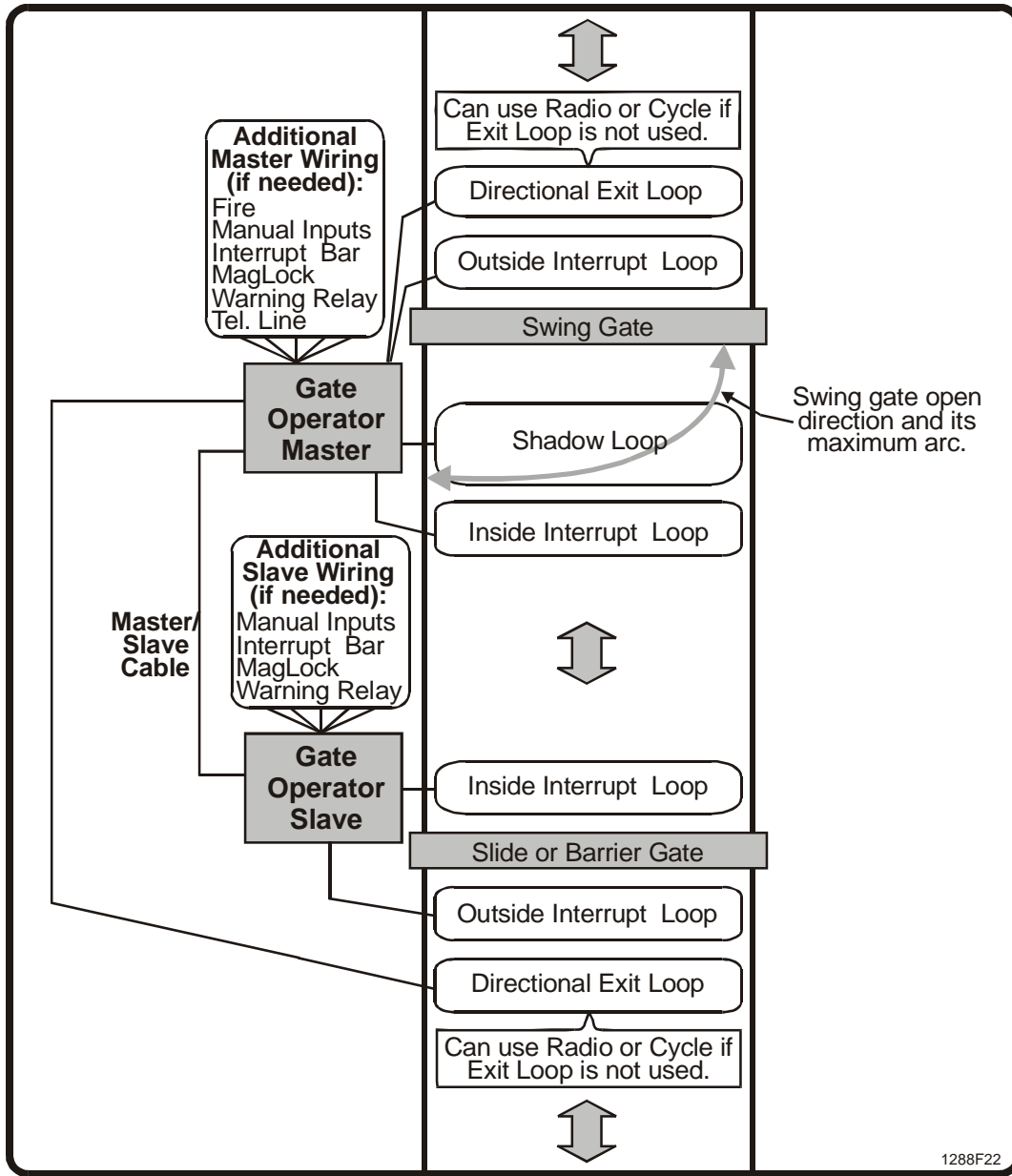

Figure 20. Bi-Directional Tandem Gate System (Swing gate, if used, opens in).

NOTE: If Radio is used, only one receiver/transmitter is required for both directions.



**Figure 21. Bi-Directional Tandem Gate System
(Swing gate opens out).**

NOTE: If Radio is used, only one receiver/transmitter is required for both directions.

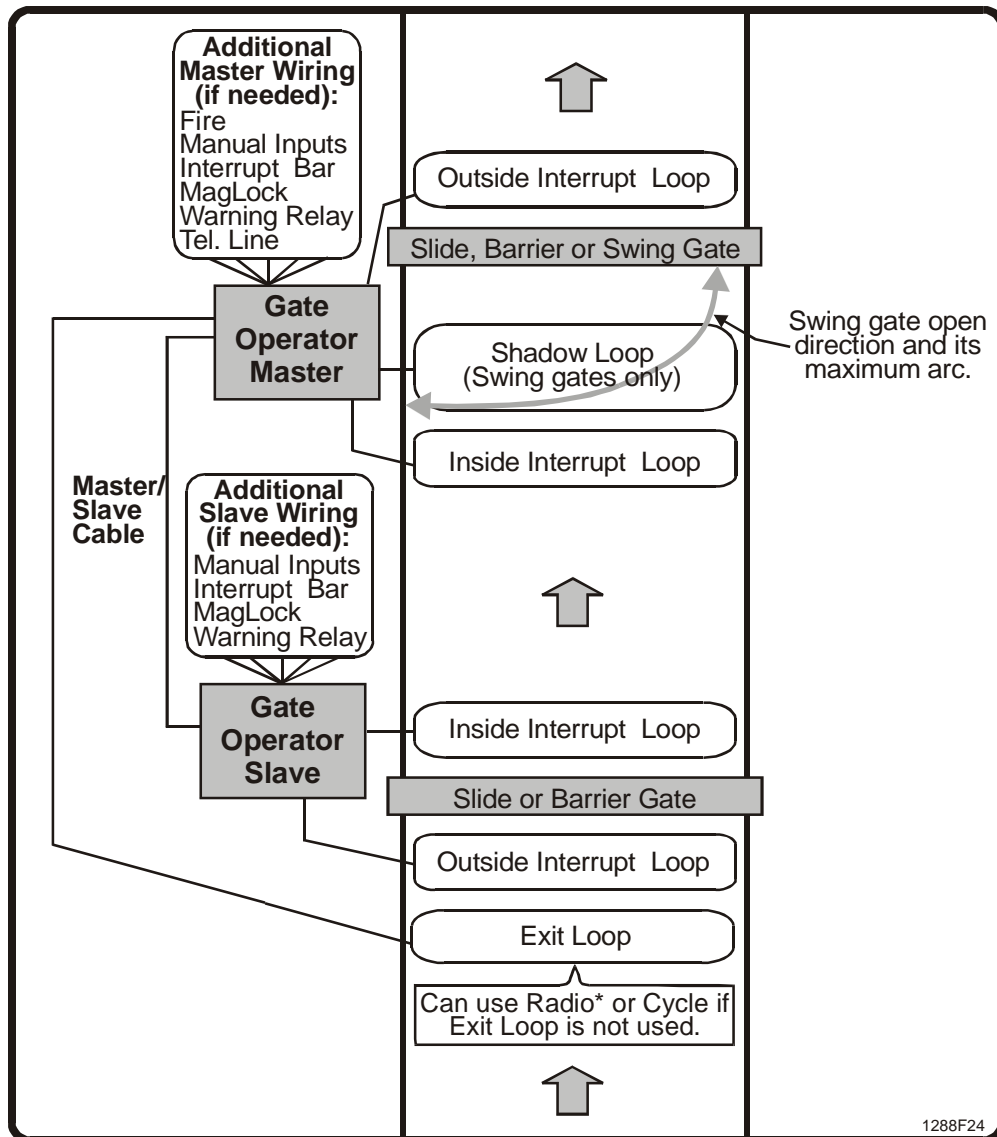

**Figure 22. Uni-Directional Tandem Gate System
(Swing gate, if used, opens in).**

*** WARNING**

If Radio is used, gate system becomes bi-directional, compromising safety and security.

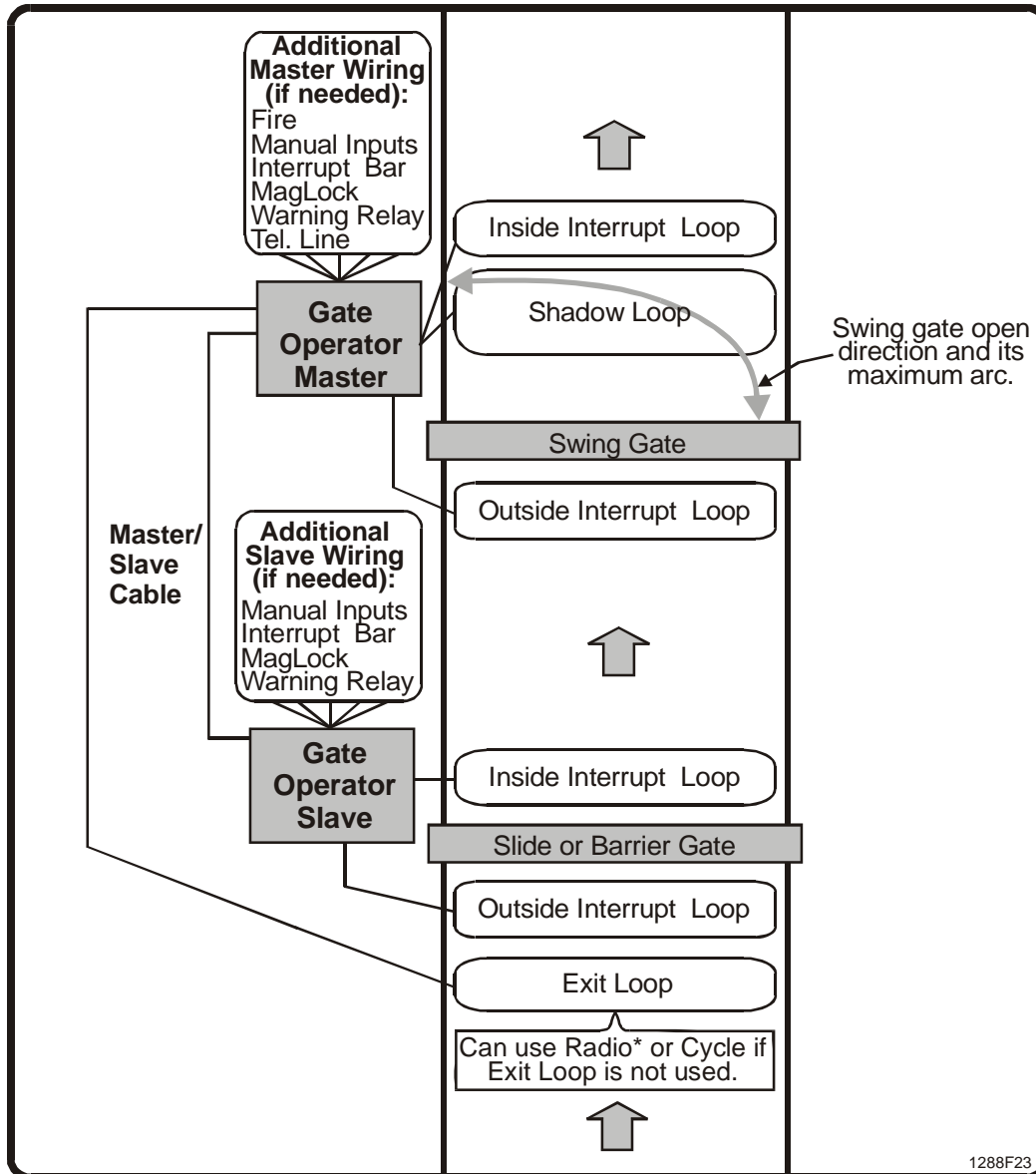

Figure 23. Uni-Directional Tandem Gate System (Swing gate opens out).

*** WARNING**

If Radio is used, gate system becomes bi-directional, compromising safety and security.

E. TROUBLESHOOTING

Units are not synchronized:

Improper Operator Pair setting. See programming step 02, Operator Type.

One gate braking to stop causes a fault in the other (moving) gate:

1. Both units are wired to the same circuit breaker.
2. Undersized power wires.

NOTICE TO CANADIAN USERS

NOTICE: The Industry Canada label identifies certified equipment. This certification means that the equipment meets telecommunications network protective, operation and safety requirements as prescribed in the appropriate Terminal Equipment Requirements document(s). The Department does not guarantee the equipment to the user's satisfaction.

Before installing this equipment, users should ensure that it is permissible to be connected to the facilities of the local telecommunications company. The equipment must also be installed using an acceptable method of connection. The customer should be aware that compliance with the above conditions may not prevent degradation of service in some situations.

Repairs to certified equipment should be coordinated by a representative designated by the supplier. Any repairs or alterations made by the user to this equipment, or equipment malfunctions, may give the telecommunications company cause to request the user to disconnect the equipment.

For their own protection, users should ensure that the electrical ground connections of the power utility, telephone lines and internal metallic water pipe system, if present, are connected together. This precaution may be particularly important in rural areas.

Caution: Users should not attempt to make such connections themselves, but should contact the appropriate electric inspection authority, or an electrician, as appropriate.